

Heavy Duty Clutches and Brakes for Energy & Offshore Applications

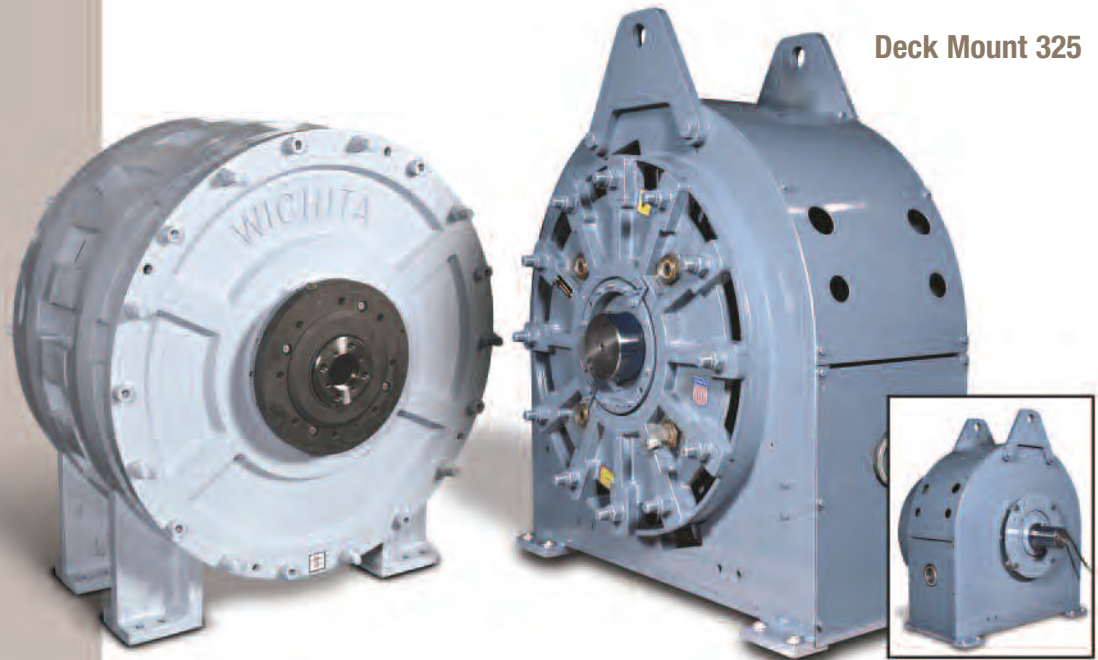

An Altra Industrial Motion Company



Deck Mount 325

**We're
Committed
to Energy &
Offshore
Applications**

Wichita Clutch supplies leaders in the energy and offshore industry with a broad product offering to meet the specific clutch and brake requirements of all types of energy applications.



**Kopper Kool Brakes Optimized
for Drawworks Applications**

Wichita Kopper Kool clutches and brakes represent the ultimate design for very high heat dissipation in the most rugged tensioning applications. Torque levels are in direct proportion to air pressure, providing accurately controlled, continuous slip braking action.

- New HICO friction material provides higher torque
- Copper alloy wear plates increase heat transfer
- Balanced water flow for the highest thermal capacity
- Durable air tube design
- Long-lasting friction material
- Integral shaft sub-assembly for optimal drawworks performance
- Saltwater corrosion package available
- Compatible with major electronic drilling systems
- Airtube has less hysteresis than piston type actuators, making it ideal for automatic drilling systems
- Packaged system can be easily removed as a unit for service if required and/or quickly swapped out for maximum rig availability
- Adjustment for wear is easily accomplished by removing shims without any unit disassembly
- Optional: Wear detection is built into the package for external monitoring

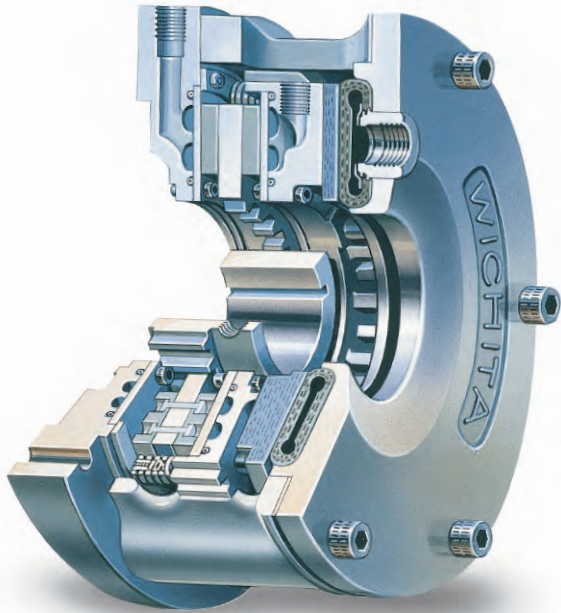

Positioning and Mooring Kopper Kool Clutches and Brakes

**Proven worldwide dependability
for offshore applications**

- Balanced water flow for the highest thermal capacity
- Durable air tube design
- Long-lasting friction material
- Saltwater corrosion package available
- Available dual actuator design

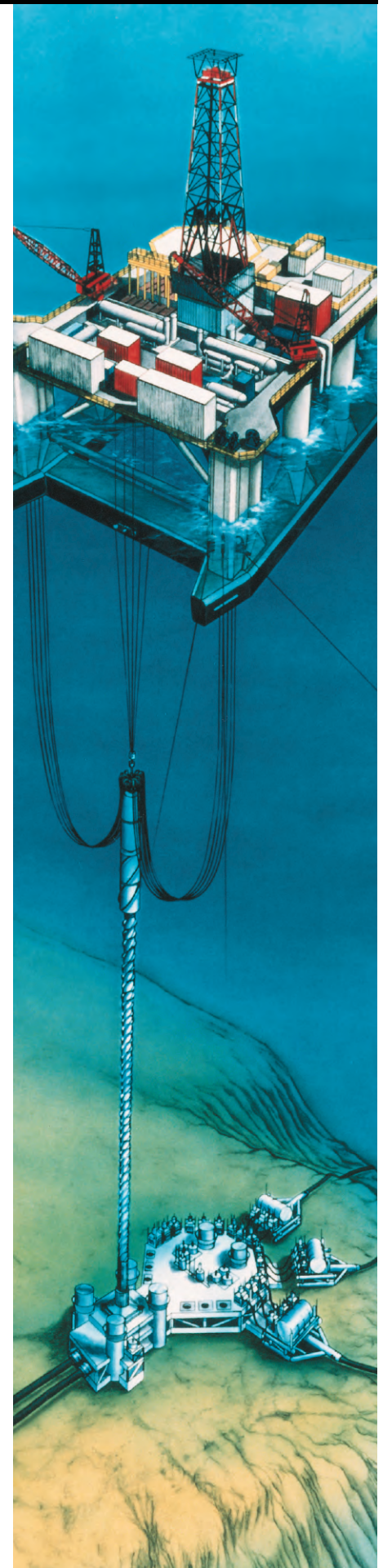

Kopper Kool Clutches & Brakes

■ Air actuated = Liquid cooled

■ Copper disc design for high heat dissipation

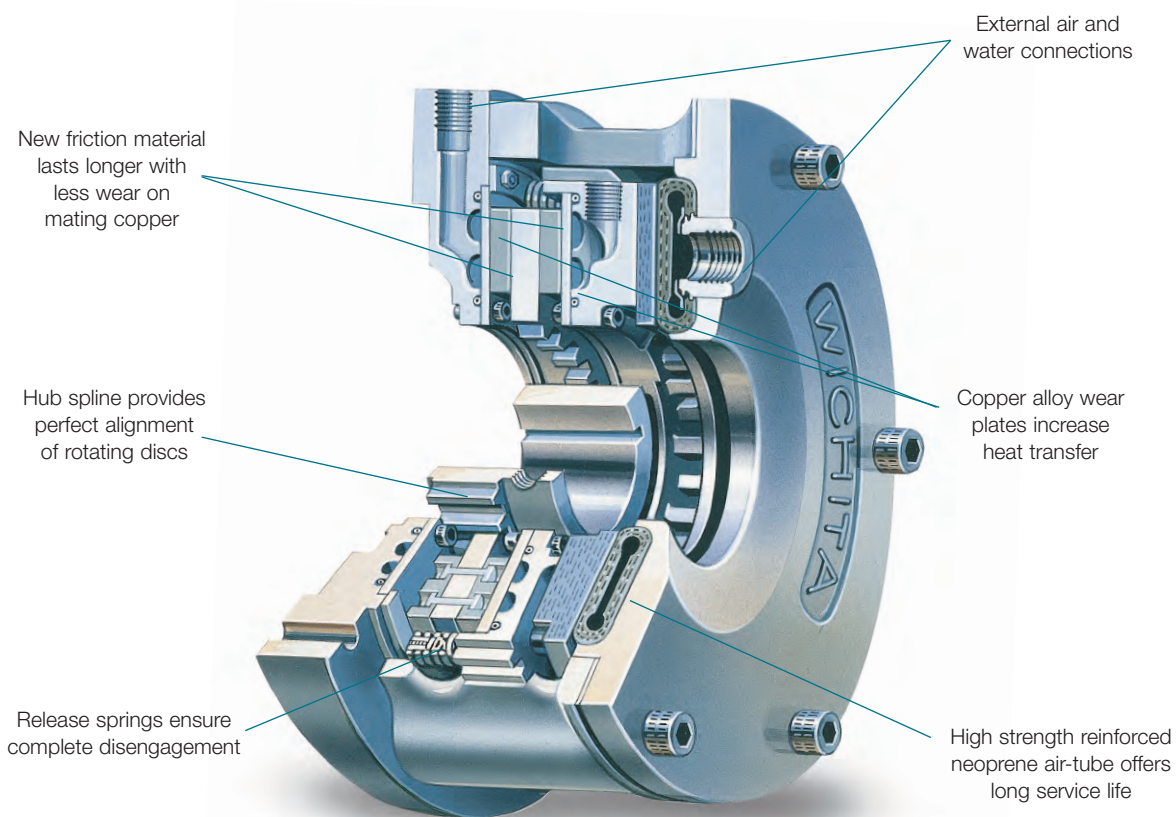

Design Features

- New friction material lasts longer with less wear on mating copper.
- Copper alloy wear plates increase heat transfer.
- Hub spline provides perfect alignment of rotating discs.
- External air & water connections.
- Release springs ensure complete disengagement.
- High strength reinforced neoprene air-tube offers long service life.
- Optional long stroke air tube available on 18" or 24" size units to increase life and standard maintenance intervals.
- High thermal capacity.

The Wichita Kopper Kool airtube disc Clutches and Brakes are liquid cooled and consist of a series of alternating discs connecting an inner drive member to an outer drive member. Engagement is achieved by pneumatic expansion of the airtube. This air-operated clutch contains copper discs for excellent heat dissipation and provides an accurately controlled continuous slip action for constant web tensioning. Tension levels are in direct proportion to air pressure applied.

Kopper Kool Brakes

| Model Size | Assembly Number | Dynamic Torque Capacity* | | | | Heat Capacity | | Max Bore Rect. Key (mm) | |
|------------|------------------------------|--------------------------|-----------|---------|---------|---------------------|-----------------------|-------------------------|-------|
| | | lb.in. | | Nm | | Series Water Hosing | Parallel Water Hosing | | |
| | | 80 PSI | 100 PSI | 5.5 BAR | 7 BAR | HP/kW | HP/kW | in. | |
| KKB 118 | 7-318-110-100-0 | 37,600 | 47,000 | 4,172 | 5,310 | 80 / 60 | 120 / 89 | | |
| KKB 218 | 7-318-210-100-0 | 75,200 | 94,000 | 8,344 | 10,620 | 160 / 119 | 240 / 179 | 5.50 | (140) |
| KKB 318 | 7-318-310-101-0 | 112,800 | 141,000 | 12,517 | 15,930 | 240 / 179 | 360 / 268 | | |
| KKB 125 | 7-326-100-100-0 | 122,920 | 153,650 | 13,640 | 17,360 | — | 350/261 | | |
| KKB 225 | 7-326-200-100-0 | 245,840 | 307,300 | 27,279 | 34,719 | — | 700 / 522 | 8.13 | (207) |
| KKB 325 | 7-326-300-101-0 | 368,760 | 460,950 | 40,919 | 52,079 | — | 1050/782 | | |
| KKB 136H | 7-337-110-300-0 | 360,000 | 450,000 | 39,947 | 50,842 | 500 / 373 | 750 / 559 | | |
| KKB 236H | 7-337-210-300-0 | 720,000 | 900,000 | 79,894 | 101,683 | 1,000 / 746 | 1,500 / 1,119 | 9.00 | (229) |
| KKB 336H | 7-337-310-300-0 | 1,080,000 | 1,350,000 | 119,841 | 152,525 | 1,500 / 1,119 | 2,250 / 1,678 | | |
| KKB 436H | 7-337-410-102-0 ¹ | 1,440,000 | 1,800,000 | 159,788 | 203,367 | 2,000 / 1,491 | 3,000 / 2,237 | | |

* Static torque will vary with temperature. Maximum air pressure is 100 PSI / 7 BAR.
 ** Maximum water jacket inlet pressure is 60 PSI. Minimum recommended air pressure is 3 PSI.
 Brakes with as great as 50% higher torque capacity is available upon request.
¹ Current design is with the Marine Corrosion package. A Non-Marine unit is available upon request.

Wichita Kopper Kool Performance Torque @ Maximum Power Rating for sizes Atd-225 & Atd-236H

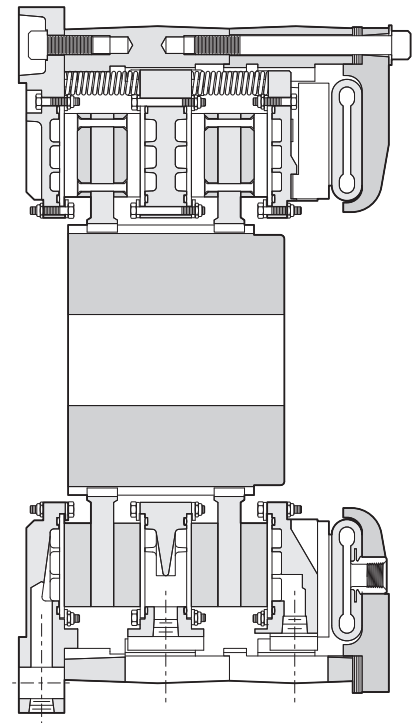
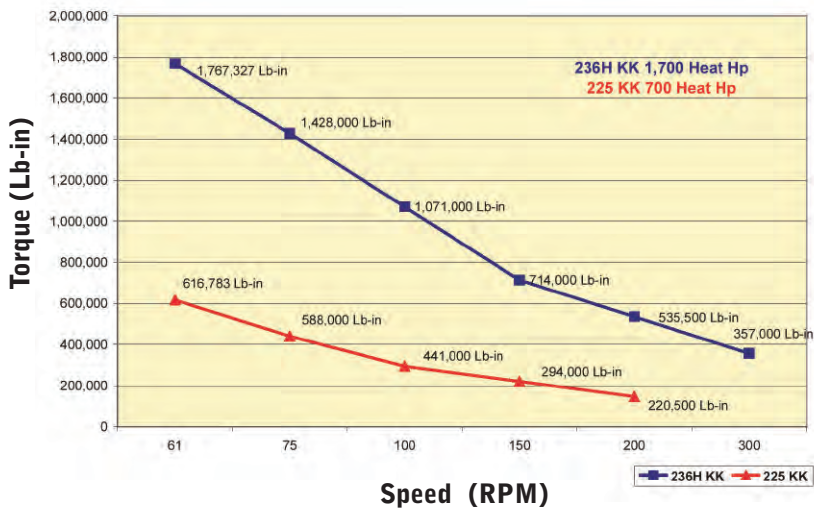

Kopper Kool Spring Set Brakes

Dimensions: inches (mm)

| Model Size ATD- | Assembly Number | lb.in. | Dynamic Torque Capacity* | | Release Pressure | | Width | |
|-------------------------|--------------------------------|-----------|--------------------------|-----------------|------------------|-------|---------|--|
| | | | Nm | PSI | BAR | in. | (mm) | |
| KKSSB 218 | 7-318-210-113-0 | 48,000 | 5,434 | 90 | 6.2 | 15.00 | (381) | |
| KKSSB 225 | 7-326-200-100-0 ¹ | 504,200 | 56,965 | 95 ⁵ | 6.5 ⁵ | 18.87 | (479.3) | |
| KKSSB 325 | 7-326-300-100-0 ^{1,2} | 756,300 | 85,448 | 95 ⁵ | 6.5 ⁵ | 23.44 | (824) | |
| KKSSB 330H | 7-331-310-300-0 ¹ | 748,900 | 84,612 | 100 | 6.9 | 22.69 | (576.3) | |
| KKSSB 236H ⁴ | 7-337-210-304-0 ² | 649,400 | 73,370 | 120 | 8.3 | 22.03 | (559.6) | |
| KKSSB 336H ⁴ | 7-337-310-107-0 ^{1,2} | 1,177,800 | 133,070 | 100 | 6.9 | 28.60 | (726.4) | |
| KKSSB 336H ⁴ | 7-337-310-106-0 ² | 940,600 | 106,270 | 120 | 8.3 | 28.60 | (726.4) | |

* Static torque will vary with temperature.

** Maximum water jacket inlet pressure is 60 PSI.

Brakes with as great as 50% higher torque capacity is available upon request.

¹ Current design is with enhanced linings. A unit with regular linings is available upon request.

² Current design is with the Marine Corrosion package. A Non-Marine unit is available upon request.

³ Current design is without hub. A unit with hub is available upon request.

⁴ Mounting same as 436H KK except with 42.500" (1,079.5 mm) hole circle.

⁵ Balance pressure.

Feature Differences: The KKSS brake uses air to release the brake, where as the KKSS-HYD brake uses hydraulic pressure to release the brake.

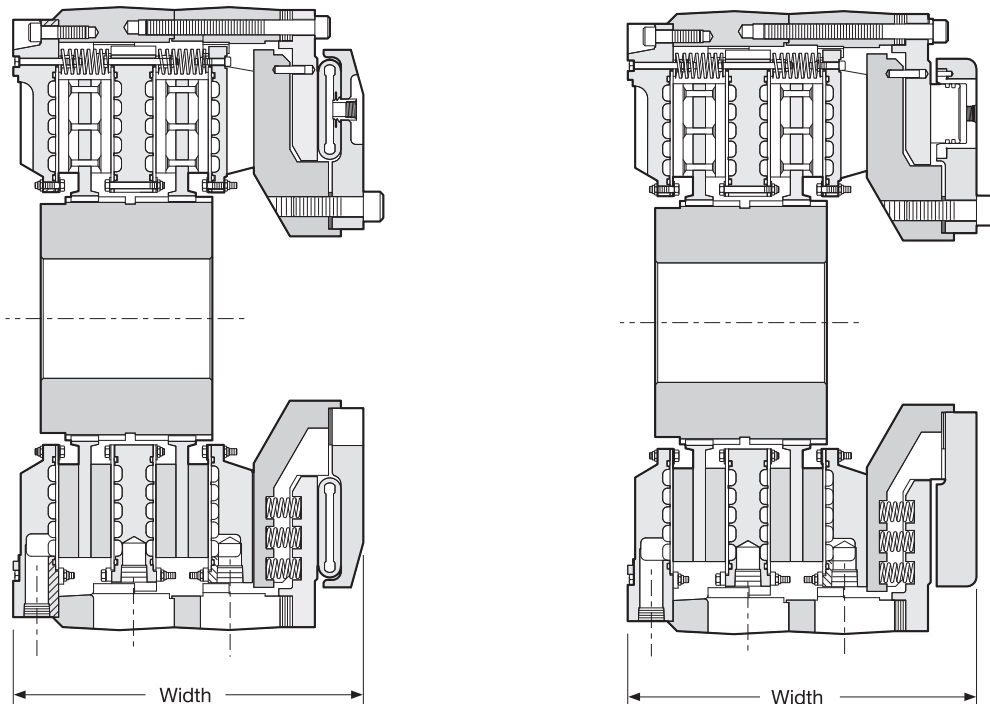

Kopper Kool Spring Set Clutch

Dimensions: inches (mm)

| Model Size ATD- | Assembly Number | Dynamic Torque | | Heat Capacity HP(kW) | Roto - Coupling NPT | Max. Speed R/C RPM | Unit RPM | Width in.(mm) |
|--------------------|--------------------------------|------------------------------------|--------------------------|------------------------------|---------------------------|--------------------------|-------------|------------------|
| | | Capacity* with Release Pressure | | | | | | |
| | | lb.in.(Nm) | PSI (BAR) | | | | | |
| KKSSC 225 | 6-326-200-100-0 ^{1,2} | 504,200 (56,965) | 90 ⁸ (6.5) | 700 (522) | 2" | 250 | 460 | 45.00 (1,143) |
| KKSSC 325 | 6-326-300-100-0 ¹ | 756,300 (85,448) | 90 ⁸ (6.5) | 1,050 (782) | 2" | 250 | 460 | 49.57 (1,259) |
| KKSSC 236H | TBD ^{2,3} | 542,100 (61,247) | 100 (6.9) | 1,300 (975 ⁶) | 2" | 250 | 300 | 32.25 (819.2) |
| KKSSC-HYD 236H | 6-337-210-100-0 ^{2,3} | 542,100 (61,247) | 1,450 (100.0) | 1,300 (975 ⁶) | 2" | 250 | 300 | 32.25 (819.2) |

* Static torque will vary with temperature.

** Maximum water jacket inlet pressure is 60 PSI.

Brakes with as great as 50% higher torque capacity is available upon request.

¹ Current design is with enhanced linings. A unit with regular linings is available upon request.

² Current design is with the Marine Corrosion package. A Non-Marine unit is available upon request.

³ Mounting same as 436H KK except with 42.500" (1,079.5 mm.) hole circle.

⁵ Series hosing

⁶ Parallel hosing

⁷ Partial-parallel hosing

⁸ Balance pressure

Feature Differences: The KKSS clutch uses air to release the clutch, where as the KKSS-HYD clutch uses hydraulic pressure to release the clutch.

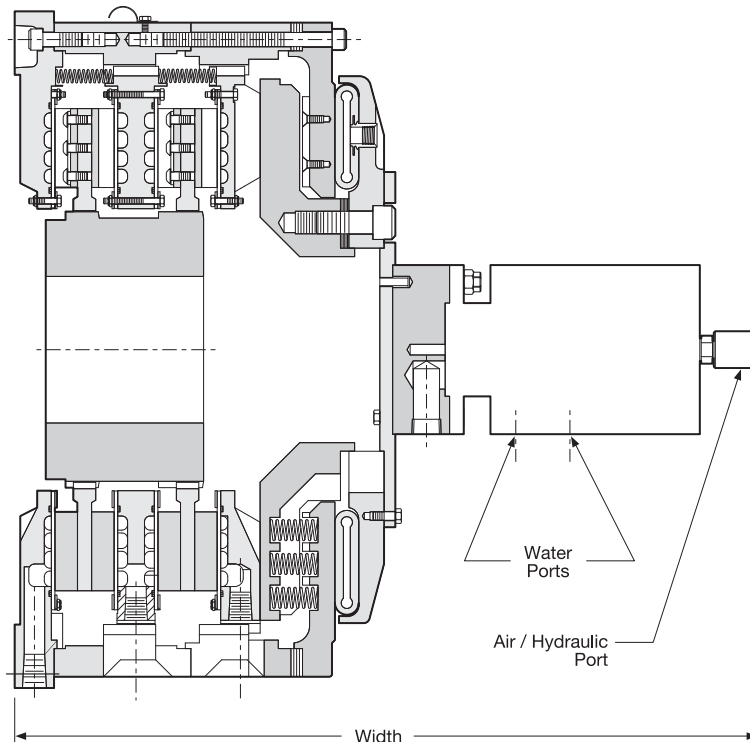

Air Cooled Spring-Set Brakes

Specifications:

| Model Size ATD- | Assembly Number 60 PSI Release | Slip Torque Capacity | | | | | | Max. Bore Rect. Key in. (mm) |
|--------------------|--------------------------------------|----------------------|------------------|-----------|---------|---------------|---------|------------------------------------|
| | | 60 PSI | lb.in. 75 PSI | 90 PSI | 4.1 BAR | Nm 5.2 BAR | 6.2 BAR | |
| SSB 118 | 7-118-100-100-0 | 31,400 | 40,400 | 51,600 | 3,548 | 4,564 | 5,830 | |
| SSB 218 | 7-118-200-100-0 | 60,000 | 77,000 | 100,000 | 6,779 | 8,700 | 11,298 | 4.75 (120) |
| SSB 318 | 7-118-300-100-0 | 80,900 | 102,000 | 122,000 | 9,140 | 11,524 | 13,784 | |
| SSB 124H | 7-125-100-100-0 | 75,500 | 86,600 | — | 8,530 | 9,784 | — | |
| SSB 224H | 7-125-200-100-0 | 137,000 | 161,200 | — | 15,478 | 18,213 | — | 6.00 (152) |
| SSB 324H | 7-125-300-100-0 | 178,900 | 223,600 | — | 20,212 | 25,263 | — | |
| SSB 136H | 7-137-100-100-0 | 254,500 | 300,000 | 400,000 | 28,754 | 33,894 | 45,193 | 9.00 (229) |
| SSB 236H | 7-137-200-100-0 | 477,500 | 564,000 | 760,000 | 53,949 | 63,722 | 85,866 | |
| SSB 336H | 7-137-300-100-0* | 675,000 | 840,100 | 1,012,600 | 76,263 | 94,916 | 114,405 | 10.00 (254) |
| SSB 436H | 7-137-400-102-0 | 868,800 | 1,081,300 | 1,303,400 | 98,158 | 122,167 | 147,260 | |
| SSB 148 | 7-148-100-300-0 | 698,250 | | | 78,889 | | | |
| SSB 248 | 7-148-200-300-0 | 1,335,000 | | | 150,830 | | | 18.00 (455) |
| SSB 348 | 7-148-300-103-0 | 1,726,000 | | | 195,006 | | | |

* Not the standard 60 PSI release pressure.

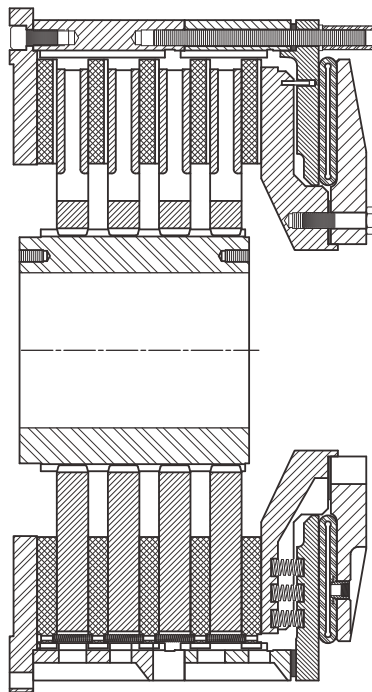

Low Inertia and Air Tube Disc Clutches and Brakes

Air actuated, modular clutch and brake combinations

Air Tube design provides fast response with smooth engagement

Clutch Combinations

- Low Inertia
- Low Inertia High Torque

Brake Combinations

- Low Inertia
- Low Inertia Spring-Set

Low Inertia Clutches and Brakes

Wichita Low Inertia Clutches and Brakes are designed to be completely free from effects of centrifugal force and self energization. They provide the high speed acceleration and deceleration essential for today's process equipment. The low-inertia designs reduce power consumption and heat build-up in cycling applications. A quick energizing air tube provides fast response with smooth engagement. They combine all the best features of the disc type clutch with all the advantages of direct air engagement through direct axial pressure application in a special composition full-circle tube.

Wichita clutches engage smoothly without noise, shock or impact and release completely in a fraction of a second. Extremely fast action is possible because of the small volume of air required. Torque developed is in direct proportion to air pressure applied.

Clutches may be slipped moderately to control the acceleration rate. When large inertia loads are powered from electric motors, smooth, controlled slip starts by Wichita Clutches can

keep power demands below the allowed maximum. Heat generated by controlled slipping or high cycle rate operation is dissipated by the centrifugal blower design of these units. These clutches and brakes interface well with automated controls through simple air and/or electric circuits.



High Torque Clutch

Wichita High Torque Clutches provide the highest torque to size ratios of any Wichita clutch. They provide smooth controlled starts and stops and are designed for minimum power loss due to low rotating inertia.

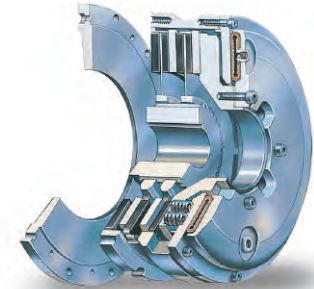
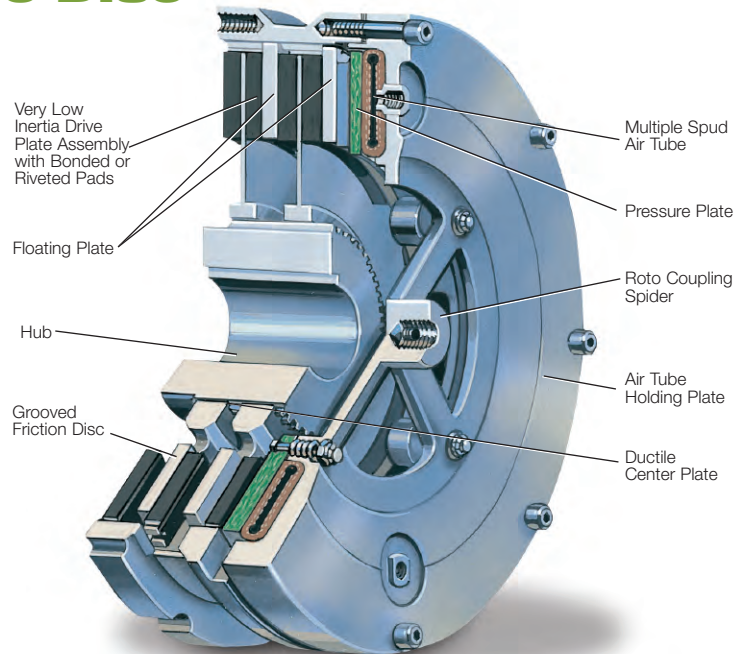

Spring-Set Brake

Wichita Spring-Set Air Release Brakes are ideal for fail safe protection of process equipment. Constructed of high strength cast iron, this improved design has thick friction discs for longer wear life. The fast acting air tube design assures quick, smooth stops.

Common Features for High Torque Clutch and Spring-Set Brake

- Thick, full circle friction discs for longer life
- Extremely fast response
- No lubrication
- High torque to size ratio
- Low rotating inertia

Genuine Replacement Parts

Longer Life

We have years of experience in building value into every Genuine Wichita Replacement Part. Our parts, made with quality materials and leading-edge technology, not only last longer than the competition, resulting in lower life cycle costs, they also fit precisely to give you the assurance of trouble-free performance. That's why we can confidently offer you the very best warranty in the business.

Faster Delivery

To help you lessen downtime problems, we've recently established new methods and procedures that will get Genuine Replacement Parts to you quicker than ever before. We've improved order processing, increased manufacturing capacities and added to our nationwide network of distributors. Many of our parts can now be shipped within 24 hours of your order or are available off-the-shelf from your local distributor. You don't have to pay a premium price for all the product and service advantages of Genuine Wichita Replacement Parts. You'll find our prices to be very competitive with any of the companies offering imitation replacement parts.

Warranty

When you specify Genuine Replacement Parts from Wichita you automatically expect more...and get more. Especially better performance, longer life and the peace of mind that comes with knowing you are working with the industry's proven leader. To further back up our quality commitment to you, we now offer a new three-year warranty on our line of replacement air tubes*, and a two-year warranty on all other components**. That's unmatched by anyone in our industry...and for good reason.

Air Tubes

- Wear resistance polymers insure compatibility with other Wichita parts
- Consistent size allows ease of replacement if required
- Low air volume construction reduces needless use of compressed air
- Combination of space-age fibers and elastomers give extended life and retention of size and fit



Friction Discs

- Special high strength materials with molded composite teeth resist functional wear and provide additional output torque
- Exactly match the mating Wichita component for consistent and maximum high torque output
- High heat resistance to combat unforeseen application problems
- Consistent size for ease of replacement
- Air grooves provide cooling and longer life



* Split air tubes are not intended for permanent installation and, therefore, are not covered under the warranty agreement.

** The warranty does not cover replacement or refurbishment of normal wear items.

**For after hours
emergency service,
call 1-940-631-4595.**

Altra Industrial Motion provides single-source convenience and world-class service

For over a century, the most important breakthroughs in engineered power transmission have been lead by Wichita Clutch, Warner Electric, and Marland Clutch. Today, these companies, and several others, are working together to lead the next century of innovations in power transmission technology. This is what Altra Industrial Motion is all about.

With a full complement of mechanical and electrical solutions for every type of application, Altra Industrial Motion stands alone as the industry's most fully committed supplier of power transmission solutions.

World-Class Engineering

- State-of-the-art CAD/CAM, 3D solid modeling and analytical capabilities
- Web-based, electronic document management system
- Application engineering support
- Six Sigma driven in engineering/manufacturing processes

Superior Customer Service and Application Support... Worldwide

Our team in the field is more than salespeople... they are experienced application specialists who understand your production process and challenges and can recommend the right power transmission solution. Our customer service and tech support teams are well trained and ready to help.



The Driving Force: The Altra Business System

All our business units subscribe to a standard of quality derived from the Altra Business System (ABS), a series of progressive manufacturing methods designed to continuously improve power transmission production and implemented to ensure that we provide the consistently superior products in demand from today's industrial marketplace.



Extensive Training Programs

We offer a wide variety of training opportunities to help you become familiar with all of our product lines, specifications and typical applications. Whether it's in one of our facilities or at your plant or office, we can put the right training program together to meet your needs.

| | | | |
|--|---|--|--|
| <p>Electromagnetic Clutches and Brakes</p> <p>Warner Electric <i>Electromagnetic Clutches and Brakes</i> New Hartford, CT - USA 1-800-825-6544 <i>For application assistance: 1-800-825-9050</i></p> <p>St Barthelemy d'Anjou, France +33 (0) 2 41 21 24 24</p> <p><i>Precision Electric Coils and Electromagnetic Clutches and Brakes</i> Columbia City, IN - USA 1-260-244-6183</p> <p>Matrix International <i>Electromagnetic Clutches and Brakes, Pressure Operated Clutches and Brakes</i> Brechin, Scotland +44 (0) 1356 602000 New Hartford, CT - USA 1-800-825-6544</p> <p>Inertia Dynamics <i>Spring Set Brakes; Power On and Wrap Spring Clutch/Brakes</i> New Hartford, CT - USA 1-800-800-6445</p> | <p>Couplings</p> <p>Ameridrives Couplings <i>Mill Spindles, Ameriflex, Ameridisc</i> Erie, PA - USA 1-814-480-5000</p> <p><i>Gear Couplings</i> San Marcos, TX - USA 1-800-458-0887</p> <p>Bibby Turboflex <i>Disc, Gear, Grid Couplings, Overload Clutches</i> Dewsbury, England +44 (0) 1924 460801 Boksburg, South Africa +27 11 918 4270</p> <p>TB Wood's <i>Elastomeric Couplings</i> Chambersburg, PA - USA 1-888-829-6637 – Press #5 <i>For application assistance: 1-888-829-6637 – Press #7</i></p> <p><i>General Purpose Disc Couplings</i> San Marcos, TX - USA 1-888-449-9439</p> <p>Ameridrives Power Transmission <i>Universal Joints, Drive Shafts, Mill Gear Couplings</i> Green Bay, WI - USA 1-920-593-2444</p> <p>Huco Dynatork <i>Precision Couplings and Air Motors</i> Hertford, England +44 (0) 1992 501900 Charlotte, NC - USA 1-800-825-6544</p> | <p>Heavy Duty Clutches and Brakes</p> <p>Wichita Clutch <i>Pneumatic Clutches and Brakes</i> Wichita Falls, TX - USA 1-800-964-3262 Bedford, England +44 (0) 1234 350311</p> <p>Twiflex Limited <i>Caliper Brakes and Thrusters</i> Twickenham, England +44 (0) 20 8894 1161</p> <p>Industrial Clutch <i>Pneumatic and Oil Immersed Clutches and Brakes</i> Waukesha, WI - USA 1-262-547-3357</p> <p>Gearing</p> <p>Boston Gear <i>Enclosed and Open Gearing, Electrical and Mechanical P.T. Components</i> Charlotte, NC - USA 1-800-825-6544 <i>For application assistance: 1-800-816-5608</i></p> <p>Bauer Gear Motor <i>Geared Motors</i> Esslingen, Germany +49 (711) 3518-0</p> <p>Nuttall Gear and Delroyd Worm Gear <i>Worm Gear and Helical Speed Reducers</i> Niagara Falls, NY - USA 1-716-298-4100</p> | <p>Overrunning Clutches</p> <p>Formsprag Clutch <i>Overrunning Clutches and Holdbacks</i> Warren, MI - USA 1-800-348-0881 – Press #1 <i>For application assistance: 1-800-348-0881 – Press #2</i></p> <p>Marland Clutch <i>Roller Ramp and Sprag Type Overrunning Clutches and Backstops</i> South Beloit, IL - USA 1-800-216-3515</p> <p>Stieber Clutch <i>Overrunning Clutches and Holdbacks</i> Heidelberg, Germany +49 (0) 6221 30 47 0</p> <p>Belted Drives and Sheaves</p> <p>TB Wood's <i>Belted Drives</i> Chambersburg, PA - USA 1-888-829-6637 – Press #5 <i>For application assistance: 1-888-829-6637 – Press #7</i></p> <p>Engineered Bearing Assemblies</p> <p>Kilian Manufacturing <i>Engineered Bearing Assemblies</i> Syracuse, NY - USA 1-315-432-0700</p> <p><small>For information concerning our sales offices in Asia Pacific check our website www.altramotion.com.cn</small></p> |
| <p>Linear Products</p> <p>Warner Linear <i>Linear Actuators</i> Belvidere, IL - USA 1-800-825-6544 <i>For application assistance: 1-800-825-9050</i></p> <p>St Barthelemy d'Anjou, France +33 (0) 2 41 21 24 24</p> | | | |



An Altra Industrial Motion Company

www.wichitaclutch.com

2800 Fisher Road
Wichita Falls, TX 76302 - USA
940-723-3400
Fax: 940-723-3436

www.wichitaclutch.co.uk

Amphill Road
Bedford MK42 9RD - UK
+44 (0) 1234 350311
Fax: +44 (0) 1234 350317