

Drum Brake Type EBN

Dimensions (DIN 15435) and technical data

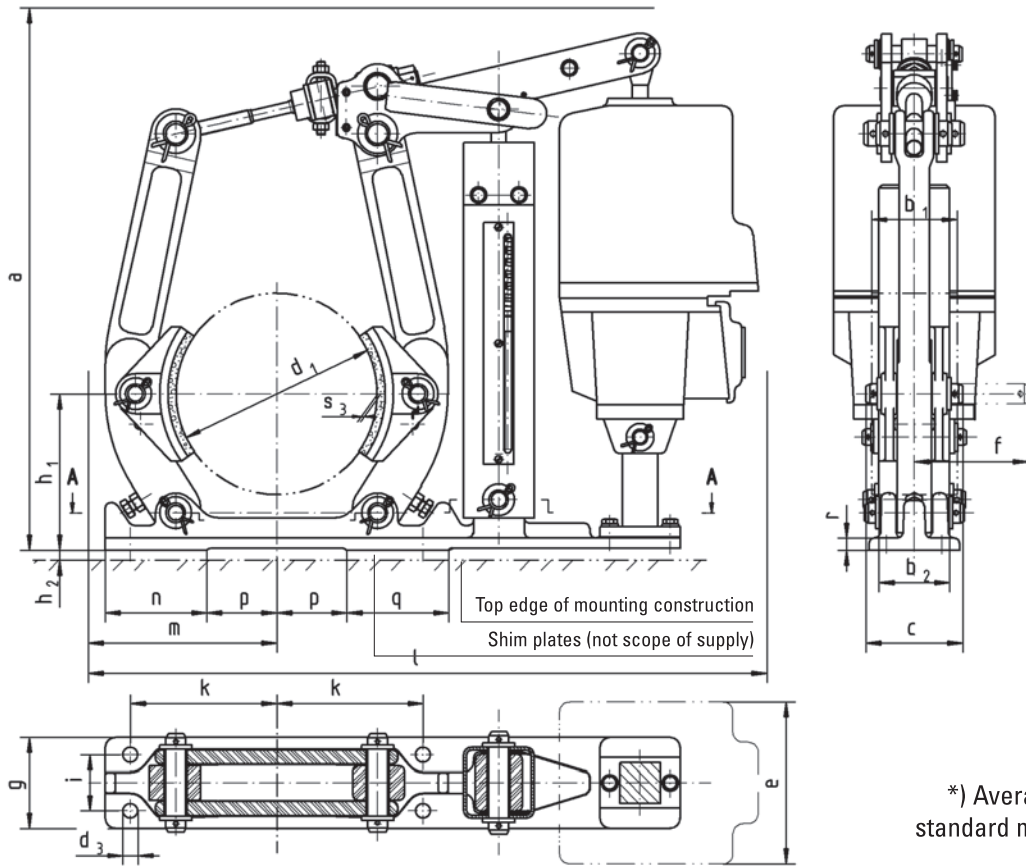

Rev. 12-06



*) Average friction factor of standard material combination

All dimensions in mm
Alterations reserved without notice

Brake type	Thruster type	$M_{BR \max}$ (Nm) $\mu=0,4^*$	a_{\max}	b_1	b_2	c	d_1	d_3	e	f	g	h_1	h_2	i	k	l_{\max}	m	n	p	q	r	s_3	kg	
EBN 200-23/5	Ed 23/5	300	500						160							665	185	100	70	100	12	1	22	
EBN 200-30/5	Ed 30/5	380	563	75	70	96	200	14	160	115	90	155	5	55	145	665	185	100	70	100	12	1	22	
EBN 200-50/6	Ed 50/6	600								195						705								
EBN 250-23/5	Ed 23/5	320	500						160							770								
EBN 250-30/5	Ed 30/5	450	572						160							770								
EBN 250-50/6	Ed 50/6	750	582	95	90	115	250	18	160	135	100	185	5	65	180	770	205	105	95	105	13	1,2	28	
EBN 250-80/6	Ed 80/6	1200								195						810								
EBN 315-30/5	Ed 30/5	540	665						160							920								
EBN 315-50/6	Ed 50/6	1000								160						920								
EBN 315-80/6	Ed 80/6	1650			118	110	140	315	18	195	165	110	225	5	80	220	1000	300	110	133	240	13	1,2	68
EBN 315-121/6	Ed 121/6	2500	790						240							990								
EBN 400-50/6	Ed 50/6	1100	680						195							1075								
EBN 400-80/6	Ed 80/6	1700			150	140	167	400	22	195	195	140	270	10	100	270	1075	310	135	165	280	15	1,5	82
EBN 400-121/6	Ed 121/6	2650	790						240							1065								
EBN 400-201/6	Ed 201/6	4000								240							1065							
EBN 500-50/6	Ed 50/6	1090	830						195							1245								
EBN 500-80/6	Ed 80/6	1870			190	180	210	500	22	195	245	170	330	10	130	325	1245	370	155	210	315	20	1,5	122
EBN 500-121/6	Ed 121/6	3010								240							1245							
EBN 500-201/6	Ed 201/6	5120								240							1245							
EBN 630-121/6	Ed 121/6	3040	990						195							1320								
EBN 630-201/6	Ed 201/6	4870			236	225	250	630	27	240	300	220	410	10	170	400	1320	450	150	280	170	25	2	196
EBN 630-301/6	Ed 301/6	6210			1015					240							1320							
EBN 710-121/6	Ed 121/6	3450	1120						195							1515								
EBN 710-201/6	Ed 201/6	5510			265	255	280	710	27	240	335	240	460	10	190	450	1515	520	150	335	175	25	2	266
EBN 710-301/6	Ed 301/6	6920								240							1515							

