

Multiconductor

Insulated Conductor Bar

TranStech[™]
POWER TRANSFER SYSTEMS

Technical Information

709 Augusta Arbor Way
Piedmont, SC 29673
800.245.4552 ph
864.277.7100 fx

transtech.com

Moving Electrification *Forward*



Complete control of all your mobile equipment

Multiconductor is a compact, reliable, and safe power supply for cranes, hoisting equipment, warehouse equipment, overhead conveyor tracks, etc.

Virtually worldwide application, in indoor and outdoor installations, even in unforgiving weather.

You are always welcome to contact us directly, refer to the back cover of this brochure for detailed information on our address.

**Moving Electrification
Forward**

Some Important Features:

Optimum reliability is assured by the advantages listed below.

Continuous copper conductors. The flat copper conductors can be pulled from rolls into the previously installed PVC housing in long continuous lengths, without any connections in the conductor.

Low maintenance. The PVC housing needs no maintenance and as previously mentioned continuous copper conductors ensure minimal brush wear. Thus minimizing the presence of carbon deposits.

Maximum power transmission. The brushes are positively located in the PVC housing and contact with the flat copper conductors is maintained by spring pressure. This guarantees a positive contact and power transmission.

Volt drop absolute minimum and constant due to continuous copper conductors, thus avoiding problems associated with added resistance at joints and increased volt drop characteristics when joints loosen or corrode.

Exceptionally long carbon brush life is achieved due to the absence of conductor joints and connectors which ensures trouble free operation.

Optimum transmission of control and data signals is achieved because of the continuous copper conductors combined with the constant and efficient contact between carbon brushes and flat copper conductors. TransTech Multiconductor is ideally suited and proven for both control and data signal transmission, such as for automated/computerized warehouse systems.

Simple installation. Due to the light weight of the PVC housing, copper conductors without connections and the design of accessory components, system installation is quick and easy.

Dust, humidity and corrosion protection. For these conditions the Multiconductor housing can be totally closed by the use of special flexible sealing strips.

No expansion problems. Due to the clearance that exists between the conductors and their location and the clearance between the PVC housing and sliding hangers, expansion due to changes in ambient temperature is accommodated without affecting the operation of the system. This also applies to extra long installations where standard components eliminate expansion problems often experienced with alternative systems.

Indoor and outdoor installation. TransTech Multiconductor can be installed both indoors and outdoors under widely varying weather conditions.

Track lengths unlimited. Extremely long track lengths are possible when required either indoors or outdoors, by utilizing the expansion joint which still incorporates continuous copper conductors.

High travel speeds. Standard up to 250 metres/minute. Higher speeds on request.

High current capacity. Copper conductors with a variation of sections can be pulled into the channels in the housing. Standard up to 320 A.

Multiconductor installations. Systems up to 7 conductors are available as standard parallel mounting systems practically all circumstances, particularly control systems, can be catered for, where the continuous conductors are of particular importance.

Compact design. By virtue of design, the Multiconductor system utilizes an absolute minimum of space.

Safety. The high standard of volume resistance of the PVC housing and the conspicuous red color ensures safety to personnel.

Degree of protection IP44. TransTech Multiconductor with flexible sealing strips meets the degree of protection IP44. Without sealing strips the degree of protection is IP23. An extra security hand safe housing is also available.

High mechanical strengths. The PVC housing has a combination of high flexural yield, impact and tensile strengths and is complemented by the design of associated components.

Self-extinguishing. For safety reasons the housing materials have a self-extinguishing feature.

Approved by Inspection authorities (UL, SEV, CSA). In various countries, TransTech Multiconductor systems are approved by Inspection Authorities (e.g. UL, SEV, CSA, etc.), where the quality and safety of equipment is essential.

Integrated Positioning System optional. For the easy positioning of movable apparatus such as skippers and travel cars, TransTech Multiconductor can be fitted with a special pulse strip and pulse detectors. With an additional PLC application, one can realize a fully automated transport system.

Housing RN7: Innumerable Possibilities and Variations!

The conductor housing RN7 is available in various models, as indicated in the summary listed below. These variations allow you to optimally gear your installation to the industrial circumstance. The housing provides the opportunity to easily adjust for variations in the occupancy of the copper conductors and to tune your installation to your changing industrial circumstances. All conductor models can be provided with flexible rubber sealings; model AS7 (refer to photograph).

Protection class of all conductor modes is IP23. The **rubber sealing AS7** is protection class **IP44**.

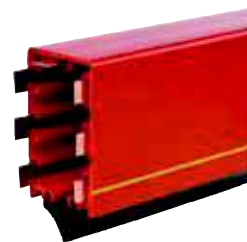

Standard Performances:

Type RN7

Color: signal red.

Temperature range as of -30 °C up to +60 °C.

The anti-reverse rib (A) in the housing ensures the collector trolley can be installed in only one way in order to prevent cross phasing. A continuous yellow stripe (B) on one side of the housing ensures correct fitting of the system. The PVC with a high impact strength is self extinguishing.

Type RN7W

Color: white. Dimensions similar to type RN7.

Temperature range as of -30 °C up to +60 °C.

When radiant heat is applicable, such as in green houses, a white conductor housing is advised.

Type RNV7

Color: grey white. Dimensions similar to type RN7.

Temperature range as of -20 °C up to +80 °C.

For applications with higher environmental temperatures.

Type RNHS7

Color: signal red.

Temperature range as of -30 °C up to +60 °C.

Due to the spacer strips on the bottom side, this conductor housing model is well suited for installations positioned at a low level.

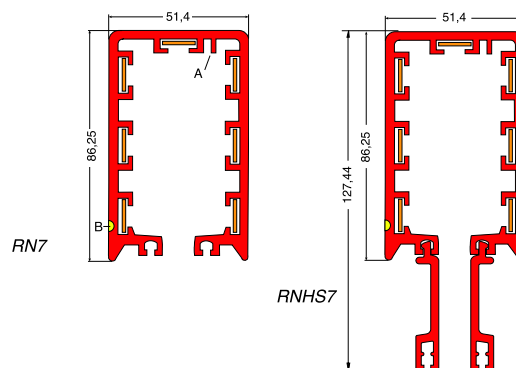

Technical data of housings

Material

Unplasticized Hard-PVC with approximate values:

Notch shock strength	5-10 kJ/m ²
E-modulus	2500-3000 N/mm ²
Softening point (Vicat)	81-83°C
Linear expansion	70.10-6 m/m/°C

Electrical Data

Volume resistivity with 100 V	>4.1015 Ω/cm
Dielectric strength with 50 Hz	>30 kV/mm
Flame class UL94	V0
Length of housing 4 m standard	

Flexible Sealing Strips AS7

Type AS7 Chloroprene, color black

This is used to ensure the suitability of a Multiconductor installation for application in a **dusty, humid**, or even **corrosive** atmosphere. Corrosion of copper conductors is nearly always prevented. This sealing is recommended for all outdoor installations and specific industries, such as, **concrete brick-works, coal storage and transhipment, dairies, galvanizing plants, textile production**, etc. Sealing strip is sold double-sided rather than single-sided; therefore if you have a 136 meter system, you need 136 meters of sealing strip.

Rail type RN(HS)7 **with AS7** meets protection degree **IP44** and is permitted to be mounted on every desired height.

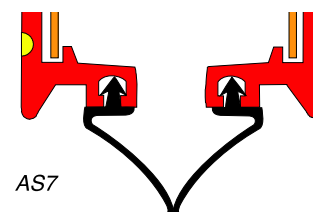

TransTech No.	Description	Red	White	4 Meter Sections	Linear 10-6 M/M/°C	Min. Temp. °C	Max. Temp. °C	HS, Extra Protection	Combined With Transfer Guides	Combined With Curves	
A1001050	PVC housing, red	RN7	x		x	70	-30	60		x	x
A1000940	PVC housing, white	RN7W		x	x	70	-30	60		x	x
A1001360	Extra Protection Extension	RNHS7	x			70	-30	60	x	x	x
A1001960	PVC housing VICAT 93	RNV7		x	x	70	-20	80		x	x
A1004030	Chloroprene Sealing Strip – per meter (both sides included)	AS7					-30	80			

Ultimate Logistical Control: Uninterrupted Feed At All Times

Each Multiconductor installation is supplied with joint-free flat copper conductors, rolled on and based on track length. (Duty Cycle 80% - see table on page 15 for complete amperage information.) Copper strips are available for current intensities of **35, 50, 80, 125, and 160A** (D.C. 80%). Material: electrolytic copper.

When 2 strips are parallel connected for each of the 3 phases of a three-phase system, current intensities of **250A** (2x125) and **320A** (2x160) are possible. The 7th conductor being

utilized as ground supply.

Upon parallel installation of various Multiconductor installations, significantly higher current capacities can be attained. By means of parallel installation the **multipole** installations can be assembled, **which is important in regard to control purposes**.

Partially due to the joint-free conductors, the Multiconductor is well suited for **control current and data transfer** when using silver-plated conductors.

Special Material Conductors

The Multiconductor system allows the application of other metals apart from copper. Silver-plated copper, which is advantageous for data transfer, is one example of possible metals that the Multiconductor system can utilize.

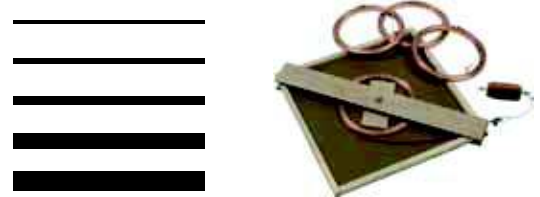

Installation of the Copper Conductors

Following the installation of the conductor housings the flat copper conductors can easily be drawn into the copper channels directly from the cable drum. This can be easily and quickly achieved by means of the copper pulling cassette, pulling block, and pulling attachment.

A simple stretchblock is supplied for conductors Cu125 and Cu160. This is designed to make installation easier and to reduce resistance on very long installations.

For applications where higher temperatures exist the resistance, and therefore the Volt drop, increases.

Solution: use the next size copper conductors.

Volt drop in V /meter Multiconductor/ A nominal current, $\cos \psi = 1, +20^\circ\text{C}$ ambient

Copper Conductor	3 phase ~	1 phase ~ en =	When utilizing 2 copper conductors in parallel, the volt drop values in the table will be halved. Impedance data can be supplied on request.
Cu35 *	0.00588	0.00679	
Cu50	0.00339	0.00391	
Cu80	0.00217	0.00251	
Cu 125	0.00119	0.00138	
Cu 160	0.00092	0.00106	
with + 35 °C multiply by 1.079; with + 45 °C multiply by 1.118; with + 55 °C multiply by 1.157.			

* Copper conductors 35A can not be combined with expansion joints

Volt Drop In Copper Conductors

By virtue of the continuous conductor concept, volt drop in the TransTech Multiconductor system is kept to an absolute and constant minimum.

With a power factor ($\cos. \psi$) of < 1 the figures mentioned in the adjacent table have to be changed accordingly, e.g. with $\cos \psi = 0.85$ the Volt drop figures have to be multiplied by 0.85.

Please see examples below. Attention: the ground conductor is always located at the yellow marker strip.

Arrangement of the Copper Conductors

The standard conductor housings and the five different copper conductors offer a vast array of possible combinations.

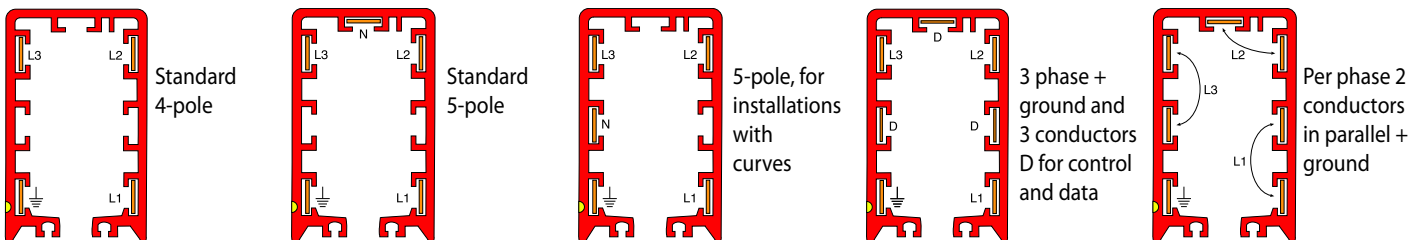

TransTech No.	Description	U/M is meters	max In (A) (ID=80%)	dimension mm (b x d)	linear exp. K-6 10-6 m/m/°C	DC resistance Ω/m	Specific Conductance (ρ) Sm/mm ²	max. length track part		
								Δt 25 °C	$\Delta t > 25^\circ\text{C}$	
A1002170*	Copper conductor 35A	Cu35	x	35	12.7 x 0.4	17.00	0.003444882	58	90	60
A1002560	Copper conductor 50A	Cu50	x	50	12.6 x 0.7	17.00	0.001984127	58	525	525
A1002640	Copper conductor 80A	Cu80	x	80	12.5 x 1.1	17.00	0.001272727	58	325	325
A1002720	Copper conductor 125A	Cu125	x	125	12.5 x 2.0	17.00	0.0007	58	200	200
A1002870	Copper conductor 160A RN7	Cu160/7	x	160	12.5 x 2.6	17.00	0.000538462	58	150	150
A1003370	Copper conductor silv. 50A	Cu50/AG	x	50	12.6 x 0.7	17.00	0.001984127	58	525	525

* Cu35 only applicable in applications up to 80mpm.

Hangings and Fixing of the Housing: Free Expansion at All Times!

The principle of the TransTech conductor bar systems with uninterrupted conductors is based on the free expansion of the PVC housing and the internal conductors. The conductor housing is therefore suspended in sliding hangers in which the conductors can slide continuously upon changes in expansion. The conductors are fixed at the feed point by means of a fixed point clamp which is inserted during installation. Sliding hangers and fixed point clamps are available in four types for maximum adaptation to the environmental conditions. See adjacent frame.

Finishing Of Metal Sliding Hangers And Joints

Type Z - Galvanized, for **normal indoor installations**.

Type L - Galvanized + epoxy coated, for **outdoors and corrosive environments**.

Type LR - As Type L, with stainless steel bolts and nuts A2.

Type R - Stainless steel AISI304, for **corrosive environments**.

Sliding Hanger

Type BN7-Z, Type BN7-L, Type BN7-R, and Type BN7-LR

The sliding hangers are fastened to the suspension frame by means of a bolt. As such the installation can be **aligned vertically**. Center distance of hanger supports:

- 1333 mm : travel speed up to 250 m/min.;
- 1000 mm : travel speed up to >250 m/min.;
- 2000 mm : with Cu35, Cu50, Cu80, for 6- and 7-pole installations up to a max. ambient temperature difference of 40 °C.

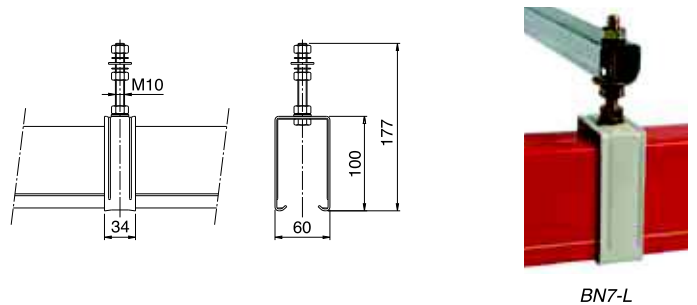

Fixed Point Clamp

Type VMN7-Z, Type VMN7-L, Type VMN7-R, and Type VMN7-LR

The complete conductor installation is to be fastened to the suspension frame by means of a self-gripping fixed-point-clamp. As of this location, the conductor housing can slide freely in the sliding hangers when expansion differences, due to temperature variation, occurs.

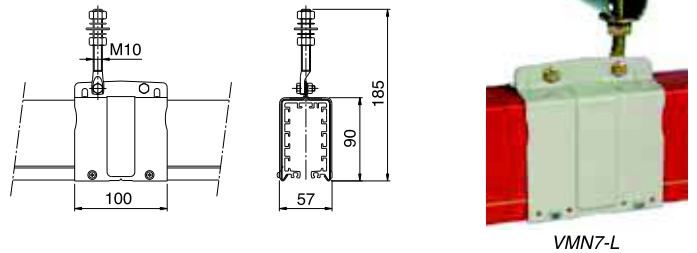

Support Bracket

- Type UH330 : l=330 mm, galvanized
- Type UH500/(R) : l=500 mm, galvanized/(SS)
- Type UH700/(R) : l=700 mm, galvanized/(SS)

These brackets have clamps attached to sliding nut assemblies, facilitating a flexible mounting arrangement. This mounting arrangement is capable of accommodating various sizes of RSJ (INP) beams, which allows for simple **horizontal alignment**.

Note: For fast mounting on site, **pre-mounted** support brackets with sliding hangers are available on request.

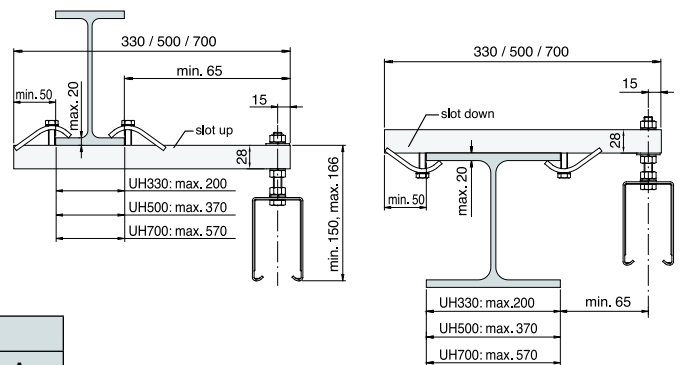

TransTech No.	Description		Ambient is		
			Dry	Humid	Chem. Agr.
A1004570	Sliding hanger galvanized	BN7-Z	x		
A1004650	Sliding hanger epoxy coated	BN7-L		x	
A1004420	Sliding hanger galv.+epoxy+A2	BN7-LR			x
A1005540	Sliding hanger SS-A2/304	BN7-R			x
A1005200	Rolling hanger galvanized	RB7	x	x	
A1004960	Fixed point clamp galvanized	VMN7-Z	x		
A1005070	Fixed point clamp galv.+epoxy coat.	VMN7-L		x	
A1005310	Fixed point clamp galv.+epox.+A2	VMN7-LR			x
A1005770	Fixed point clamp A2/304	VMN7-R			x

TransTech No.	Description	Length (mm)
A1018010	Support bracket galvanized 330mm UH330	330
A1018160	Support bracket galvanized 500mm UH500	500
A1018320	Support bracket galvanized 700mm UH700	700
A1018370.B0000	Support bracket stainl. steel 330mm UH330-R	330
A1018380	Support bracket stainl. steel 500mm UH500-R	500
A1018390	Support bracket stainl. steel 700mm UH700-R	700

Joint Clamps: For the Simple Connection of Conductor Housings

The lengths of the housing are connected by means of standard joint clamps. There are 2 variations:

- standard metal joint clamp
- ABS expansion joint clamp

Metal joint clamps are available in 4 types, to ensure maximum tuning to the operating conditions. Please refer to the upper right frame on page 3.



VN7-Z

Joint Clamp

Type VN7-Z, Type VN7-L, Type VN7-R, and Type VN7-LR

The conductor housings are connected by means of a self-gripping joint clamp. The self-drilling screws, as supplied, ensure an extra firm connection with longer system lengths (from 80m length 2 pc. per joint; from 200m length 4 pc. per joint).

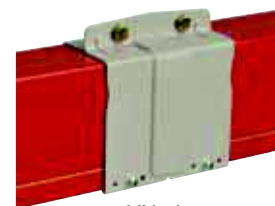
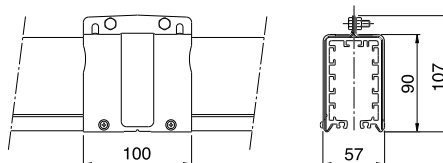

VN7-L

Insulating Tape

Type T50 (50 mm width, roll of 10 m)

This adhesive tape is used to ensure a permanent shroud around the housing joints, prior to fitting the joint clamps, for both indoor and outdoor installations. 1 roll is sufficient for 35 joints.

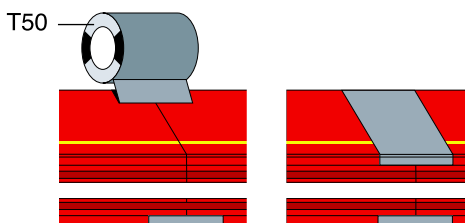

Expansion Joint

Type KEV7

This ABS expansion joint is applied when a free expansion of the Multiconductor from one fixed point is not possible. Such as with very long installations, tracks in which there are several current supply connections, closed curved tracks, etc.

The PVC housing is then fixed to the support construction with a fixed point clamp adjacent to an expansion gap at recommended positions.

Important: Read the supplied mounting instructions carefully **before** mounting, to determine the expansion gaps. If in doubt, please consult TransTech.

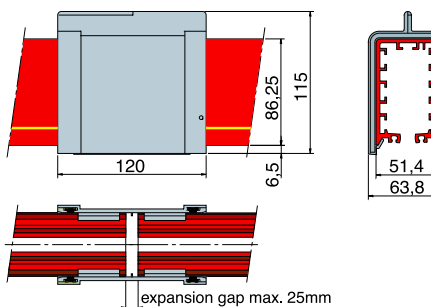

KEV7

The rubber sealing at the inner side of the synthetic expansion joint clamp, together with the continuous AS7 sealing strips, also allows installations **outdoors**.

Installations with expansion joints require collector trolleys type “./E” (see page 11).

TransTech No.	Description	Ambient Is			with VN7-.	with VN7- and humidity	V max with humidity	max. free expansion in joint (mm)
		Dry	Humid	Chemical Agress.				
A1004730	Joint clamp galvanized VN7-Z	x					400V	0
A1004810	Joint clamp galv/epox.VN7-L		x				400V	0
A1004340	Joint clamp galv.+epox.+A2 VN7-LR			x			400V	0
A1005620	Joint clamp A2/304 VN7-R			x			400V	0
A1006040	Insulating tape 10m x 50mm T50				x	x		
A1005461	Expansion joint KEV7	x	x	x			400V	25

End Feed Boxes

Efficient and Reliable Solutions

End feed boxes are used for the connection of the feeding cable to the outer end of the Multiconductor system (see picture).

All feed boxes are fitted with metric glands. It is possible to use extra glands and/or several diameter ranges from type EB40.

An end feed clamp (EC160) is required for connection of copper for each 125A or 160A conductors (see details below).

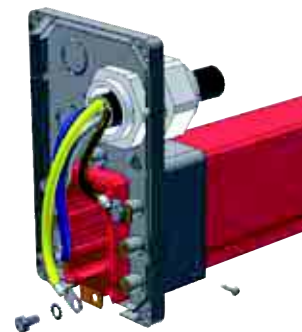

EB40 (opened)

End Feed Boxes

Type EBS32

Compact end feed box with cable gland M32, suitable for cables Ø10-Ø21 mm. Connecting screws M6 included.

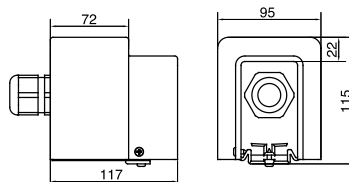

EBS32

Type EB40

End feed box for with cable gland M40, suitable for cables Ø16-Ø28 mm. The push-through holes offer easy mounting of various cable glands. Connecting screws M6 included.

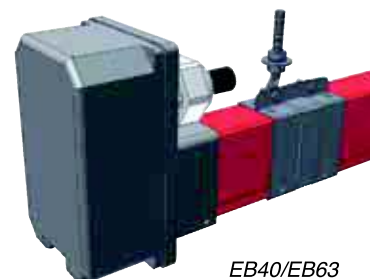
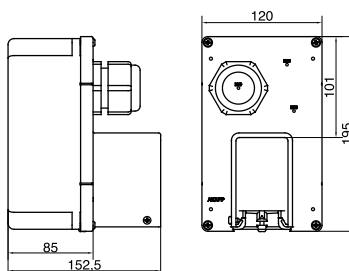

EB40/EB63

Type EB63

As end feed box EB40, but with cable gland M63, suitable for cables Ø30-Ø44.5 mm. Connecting screws M6 included.

End Feed Clamps

Type EC160

Required for connecting copper conductors 125A or 160A to the cable lug of the connection cable. To be ordered separately.

Special arrangements and gland sizes available upon request.

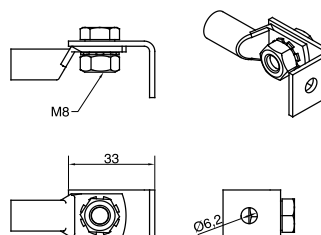

EC160

TransTech No.	Description	Max. Temp. (°C)	Range of Diameter Feeding Cable (mm)	Max. Copper Conductors Mounted	I max (80% D.C.) Non-parallel (A)	Protection Degree Without AS7	Protection Degree With AS7	
A1006830	End feed box 1xM32	EBS32	80	10 - 21	4xCu80 / 7xCu50	80	IP23	IP44
A1006800	End feed box 1xM40	EB40	80	16 - 28	4xCu125 / 7xCu80	125	IP23	IP44
A1006810	End feed box 1x63	EB63	80	30 - 44	4xCu160 / 7xCu80			
A1006820	End feed box	EB	80	no glands			IP23	IP44
A1013010	End feed clamp (req. if Cu125 or Cu160)	EC160	80			160		

Line Feed Boxes: Designed for More Flexibility

A line feed is used for the connection of the feeding cable to any location along the system – middle, end, or any point in between. The line feed connection is made up of a line feed box, line feed clamp holder and feed clamps. The line feed clamp allows for a continuous strip of copper from one end of the system to the other.

The collar plates of the line feed box are each installed over the housings meeting at the feed point. Next, the line feed clamp holder (LCH) is installed between the conductor housings. Each housing is then secured with a fixed point

clamp (page 3). Conductor clamps are installed prior to pulling the copper conductor through the system. Clamps tightened on the copper, secure the copper to the housing.

The RN7-LH is used for closed loop systems or very long systems where a conductor splice is needed at the line feed box. Conductor clamps (page 7) are not used. Consult TransTech for application assistance.

After power is brought in through the feed box collar plate and wired to the conductor clamp, the line feed box cover is installed.

Line Feed Boxes Types LB

Type LB40

Line feed box for connection of copper conductors up to 125A. With 1 gland M40 for cables Ø16-Ø28 mm.

Type LB63

Line feed box for connection of copper conductors up to 160A. With 1 gland M63 for cables Ø30-Ø44.5 mm.

Type LB32-4

Similar to LB63, but with 4 glands M32 for cables Ø10-Ø21 mm.

Type LB32-7

Similar to LB32-4, but with 7 glands M32 for cables Ø10-Ø21 mm.

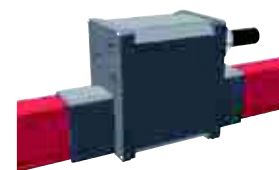
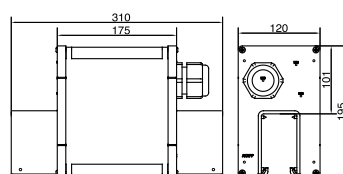

LB40/LB63

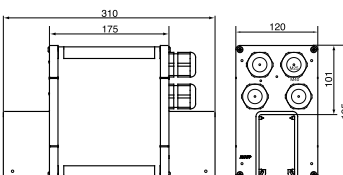

LB32-4

Line Feed Clamp Holders

Type RN7-LCH

Applicable for line feed connections with continuous copper (all sizes), irrespective of the number of poles. The required line feed clamps must be ordered separately.

Type RNHS7-LCH

Similar to RN7-LCH, but with spacer strips for use with extra hand-safe housing RNHS7.

Type RN-LH

Applicable for line feed connections with continuous copper that require joints in the line feed (i.e. in multi curved systems, very long tracks, etc.). The RN-LH is composed of two halves that “click” together around the rail housing, leaving the copper joints free. Includes bolts/nuts M6 for connections of conductors.

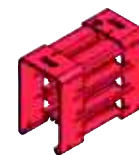
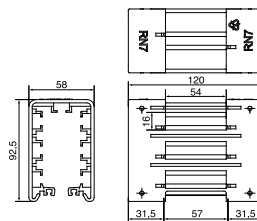

RN7-LCH

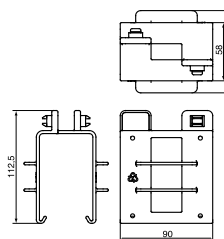

RN-LH
(mounted)

TransTech No.	Description	Max. Temp. (°C)	Range of Diameter Feeding Cable (mm)	Max. Copper Conductors Mounted	I max (80% D.C.) Non-parallel (A)	I max (80% D.C.) Parallel (A)	Protection Degree Without AS7	Protection Degree With AS7
A1006900	Line feed box 1xM40 LB40	80	16-28	4xCu125 / 7xCu80	125	-	IP23	IP44
A1006910	Line feed box 1x M63 LB63	80	30-44	4xCu160 / 7xCu125	160	250	IP23	IP44
A1006920	Line feed box 4xM32 LB32-4	80	4x 10-21	4xCu160	160	-	IP23	IP44
A1006930	Line feed box 7xM32 LB32-7	80	7x 10-21	7xCu160	160	320	IP23	IP44
A1006940	Line feed box LB	80	no glands				IP23	IP44
A1006035	Line feed clamp holder RN7-LCH	80						
A1006035.B0001	Line feed clamp holder RNHS-LCH	80						
A1006950	Set line feed RN-LH	80						

Connecting the Copper Conductors: Skillful Solutions With Clamps and Boxes

All line feed systems require clamp holders and feed clamps to connect the copper conductors within the rail housing to the cores of the supply cable (see also page 6).

There are 2 types of feed clamps: LC80 and LC200.

To connect the copper conductors to a cable terminal in a transition box, the transition cables OK25 or OK35 can be used. In some cases, it can replace a feeding cable with an overly large outer diameter.

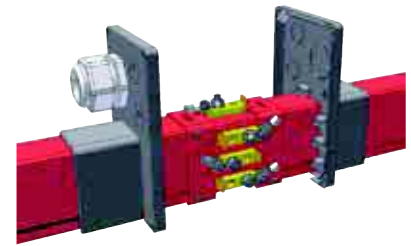

LCH + LC80

Feed Clamps

Type LC80

To be applied for mounting copper conductors Cu35 - Cu80.

Type LC200

To be applied for mounting copper conductors Cu125 - Cu160.

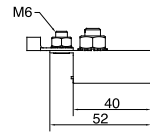

LC80

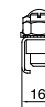
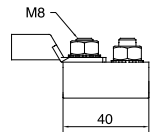
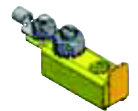

LC200



Transition Cables

Type OK25

Cable 1x 25 mm², length 1.5 m, fitted with cable lugs on both sides. For max. current capacity 125A or 250A (with 2 cables in parallel connection) and Cu125 copper conductor. To be used with Transition box OGV320 (see below).

Type OK35

Cable 1x 35 mm², length 1.5 m, fitted with cable lugs on both sides. For max. current capacity 320A (with 2 cables in parallel connection and Cu160 copper conductor). To be used with Transition box OGV320 (see below).

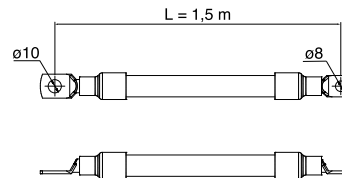

Transition cable series OK

Transition Box for Feed Connection Multiconductor

Type OGV320

Complete with 2x5 bolts M10 for cable lug connections, 7 glands PG21 and a special grommet for cables of Ø20 - Ø75 mm .

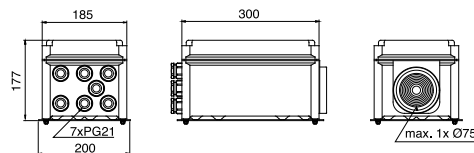

OGV320

Line Feed Clamps TransTech No.	Description	Number	Max. Current (A) (100% D.C.)	With Type Line Feed Holder
A1012750	Feed clamp small LC80	1 per conductor	72	RN7-LCH
A1013000	Feed clamp LC200	1 per conductor	179	RN7-LCH
Transition Cables TransTech No.	Description	Number	Max. Current (A) (100% D.C.)	With Type Transition Box
A1499560	Cable, 1x25 mm ² , L=1.5m OK25	1 per conductor	135	OGV320
A1499640	Cable, 1x35 mm ² , L=1.5m OK35	1 per conductor	169	OGV320
Transition Box TransTech No.	Description	Number	Max. Current (A) (100% D.C.)	Protection Degree
A1010510	Feed Connection Transition Box OGV320	1 per system	286.3	IP44

Other Components: End Caps and Inspection Units

An end cap is to be mounted for sealing off the open ends of a Multiconductor system.

In order to eliminate length differences between copper conductors and PVC housing due to temperature variations, it is important that the conductors have sufficient length within the end cap. For installations with extreme length differences, extra long end caps can be applied.

An inspection unit is fitted with two joint clamps. VN7 is in

Multiconductor installations where inspection of the trolley is not possible by removing an end cap or end feed. E.g. on endless curved tracks or on applications where several collector trolleys are fitted, or where a special location area for the inspection is available.

Alternatively, a special wooden wedge set can be used for extracting and inserting a trolley. Both possibilities are described on this page.

End Caps

Type EN7

Length 300 mm. Attached to the housing by means of a joint clamp (to be ordered separately). See photo.

Type EN7-W

Similar to EN7, but color white.

Type ENHS7

For Multiconductor RNHS7, similar to EN7, includes with distance strips.

Type ENV7

For Multiconductor RNV7. Similar to EN7, but for temperature range -20 °C to +80 °C. Color grey white. Inspection unit Type UN7 Length 200 mm. The inspection unit is fitted with 2 joint clamps VN7 in Multiconductor systems. Inspection units for curves can be supplied on request.

Type UNHS7

For Multiconductor RNHS7.

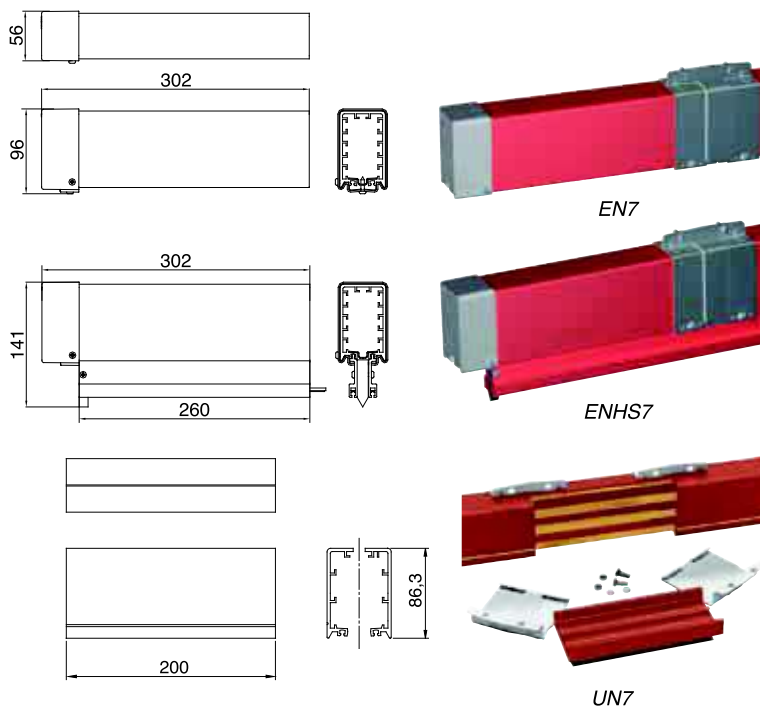

Wooden Wedge Set

Type OBA

For fast extraction and insertion of trolleys at almost any location of a Multiconductor system. The set consists of two wooden wedges with two PVC plates. By inserting the wedge into the housing and then turning it, the housing will widen and the trolley can be extracted easily. When inserting the trolley again, the two plates can be used to guide it into the housing.

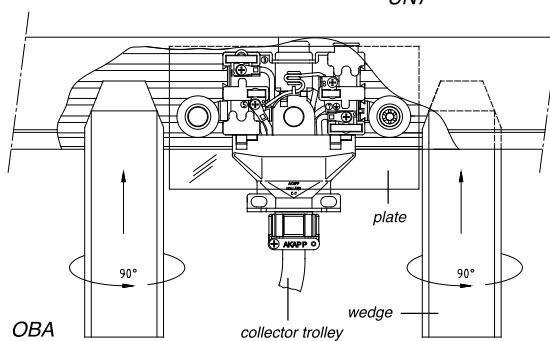

TransTech No.	Description	Length (m)	Red	White	Grey	Max. Poles	IP23	Sealing Rubber AS7 Applicable	IP44 with AS7	HS, Extra Protection
A1014140	End cap red EN7	0.30	x			7	x	x	x	
A1014800	End cap white EN7W	0.30		x		7	x	x	x	
A1014370	End cap red for RNHS7 ENHS7	0.30	x			7	x	x	x	x
A1014690	End cap for RNV7 ENV7	0.30			x	7	x	x		
A1015030	Inspection unit red UN7	0.30	x			7		x		
A1015260.B0000	Inspection unit red f. RNHS7 UNHS7	0.30	x			7		x		x

Collector Trolleys Series C7: Excellent Contact Characteristics

The C7 collector trolleys are available to suit 2 to 7 conductors, as required, and are suitable for maximum current capacity of 35A, 70A and 100A; duration of duty cycle is 60%.

The collector trolley series "CL7" are supplied with a connector cable (approx. 1 m) with numbered wires.

The standard models of the C(L)7- collector trolleys are suitable for nearly all possible situations and are easy to adjust. The summary below indicates the most commonly used models and options. The required model often depends on specific organizational circumstances.

The Standard Collector Trolley With Its Specific Characteristics:

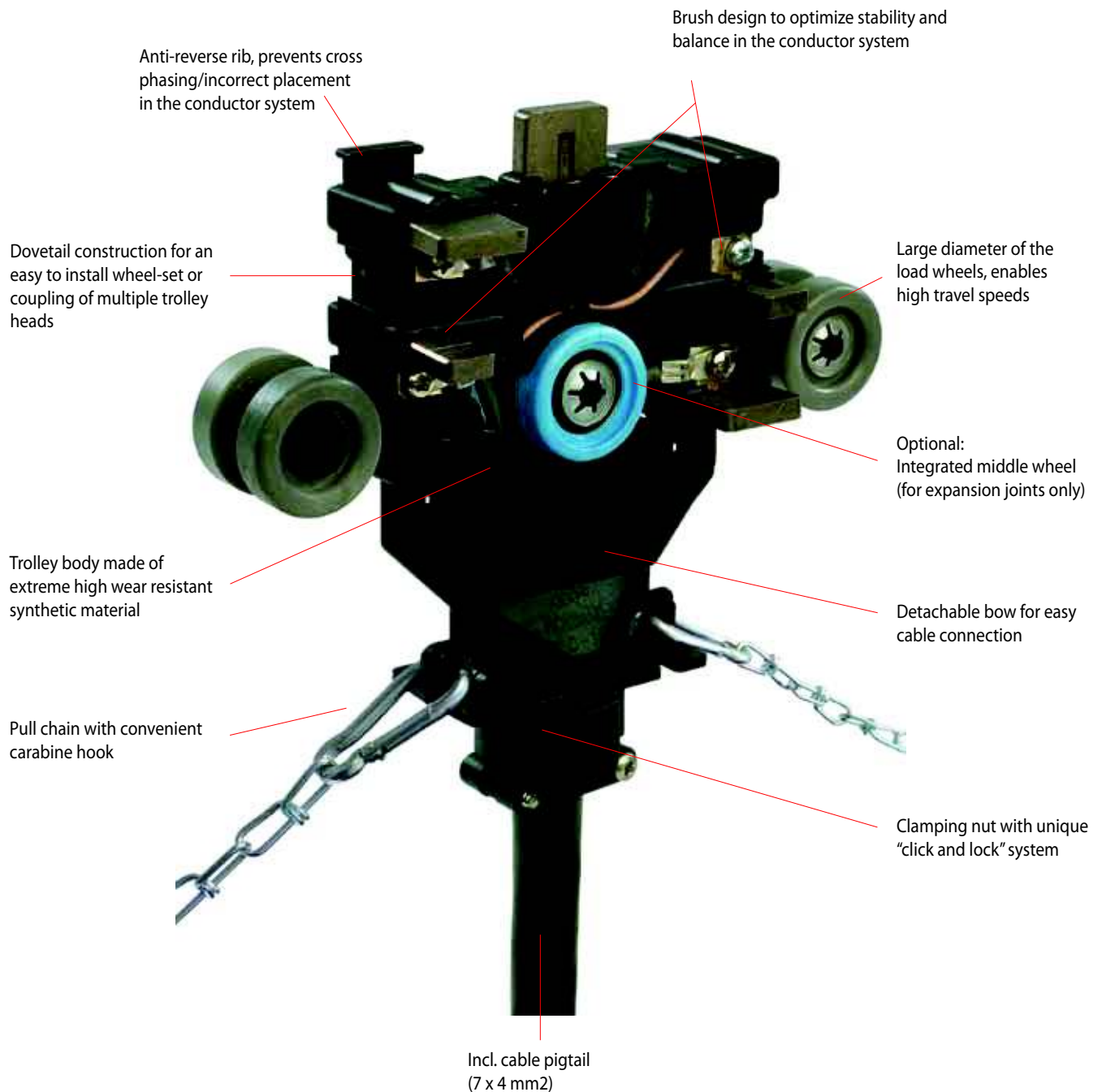

Collector Trolleys: Standard Series for High Performance

The collector trolley provides the current conduction from the Multiconductor system to your machine. The collector trolley maintains uninterrupted contact with the flat copper conductors by means of flexible, extreme wear-resistant carbon brushes manufactured from a specific bronze-carbon alloy. It is pulled along the Multiconductor system by a trolley towing arm which is mounted onto the machine. The uninterrupted copper conductors of the Multiconductor system ensure low brush wear even at extremely high trolley travel speeds.

The standard collector trolleys, supplied with low wear Nylon wheels, are suitable for **travel speeds** up to **100 m/min**. For **higher travel speeds**, for **heavy duty** and/or for **dusty environments** the collector trolleys are fitted with **dust proof, ball bearing wheels** (type "S"). See special current collectors, page 11, for **travel speeds > 250 m/min**. Special instructions for Multiconductor installation are applied.

On page 22 you'll find more information on all collector trolley series concerning maintenance and spare parts.

Collector Trolleys

Multiconductor collector trolleys are available with 2 to 7 conductors which carry current capacities of **35A, 70A, and 100A** (D.C. 60%) or **27.11A, 54.22A, and 77.46A** (D.C. 100%). Applicable from -20°C (types ..LT from -30°C) up to +80°C. See table on page 15 for complete amperage information.

These collector trolleys are fitted as standard with a supply cable. The connection with the apparatus/machine to be fed is via a transition box (ordered separately) which can be located adjacent to the collector trolley towing arm position (see page 14).

Selection Chart Of Standard Collector Trolleys + Transition Boxes

A Max.	35		70		100	
Number of Poles	Type Trolley	Type Trans. Box	Type Trolley	Type Trans. Box	Type Trolley	Type Trans. Box
2	CL7-2-35	TTB35-4	CL7-2-70	TTB70-4	CL7-2-100	TTB100-4
3	CL7-3-35		CL7-3-70		CL7-3-100	
4	CL7-4-35		CL7-4-70		CL7-4-100	
5	CL7-5-35	TTB35-7	CL7-5-70	TTB70-7	CL7-5-100	TTB100-7
6	CL7-6-35		CL7-6-70		CL7-6-100	
7	CL7-7-35		CL7-7-70		CL7-7-100	

For the application of **2 or 3 separate collector trolleys per apparatus to be fed** (e.g. for transfer installations), the following transition boxes are used:

Number of Trolleys	Type Trolleys	Type Transition Box
2 collector trolleys	CL7-2 t/m 4-35	TTB70-4
2 collector trolleys	CL7-5 t/m 7-35	TTB70-7
2 collector trolleys	CL7-2 t/m 4-70	TTB200-4-6
2 collector trolleys	CL7-5 t/m 7-70	TTB200-7-6
2 collector trolleys	CL7-2 t/m 4-100	TTB200-4-6
2 collector trolleys	CL7-5 t/m 7-100	TTB200-7-6
3 collector trolleys	CL7-2 t/m 4-35	TTB100-4
3 collector trolleys	CL7-5 t/m 7-35	TTB100-7
3 collector trolleys	CL7-2 t/m 4-70	TTB200-4-6
3 collector trolleys	CL7-5 t/m 7-70	TTB200-7-6

Carbon Brush Types		Standard Carbon Brushes		Silver Graphite Brushes*	
Application	Brush Position in Collector Trolley	TransTech No.	For Normal Conductors	TransTech No.	For Silvered Conductors
Phase brush** norm.	1, 2, 3, and 6	A1411021	K91P	A1412221	KZ91P
Phase brush** twin	4 and 5	A1410601	C91D	A1410621	CZ91D
Ground brush	7	A1410521	C91A	A1410531	CZ91A

* Silvergraphite brushes are softer than the conductors

** Also suitable for DC

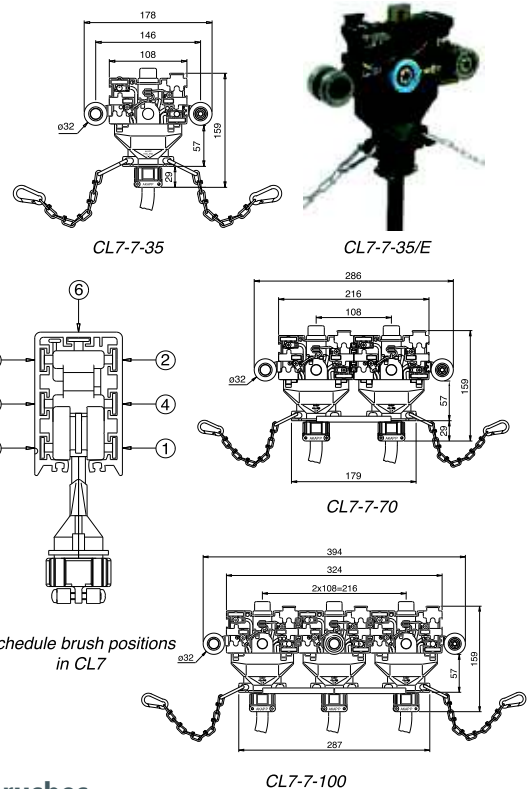

Carbon brushes

The collector trolleys are supplied as standard with carbon brushes for 35A, positioned according to the table below.

The brushes in positions 4 and 5 are both fitted as double brushes ("twin brushes"). Twin brushes are smaller than the others and their capacity is 35A per set. Advantages of this construction are a **perfectly balanced** collector trolley and an **improved transmission of control signals**.

Collector Trolleys: Adaptations for Special Applications

Apart from the numerous models of the standard collector trolleys, a vast array of special models are possible and available.

The collector trolleys of the CL7 series can easily be adapted to **exceptional circumstances** such as installations with **very high travel speeds, transfer guides, curves, expansion gaps, etc.**

The pre-mounted wheel set is appropriate for most applications; however, the dove-tail construction makes it simple to

install or exchange the wheel sets and create the trolley that fits the specific need. You can of course also order trolleys with the adaptations you need. In the table below, an overview of the possibilities is listed, together with the respective suffix. Please refer to these suffixes when ordering. For unlisted models, please contact TransTech.

Current collector trolleys series S(L)7 and NLHS7 are available for installations with curves or housing type HS, extra protection.

Collector Trolleys for Special Applications

There are a number of possibilities to adapt the standard current collector series CL7. Wheel sets are available that can be mounted or exchanged easily by means of dove-tail connections (see photo).

In the table below a number of special performances are listed with their respective suffix.

Performance	Type	Performance	Type
Expansion (KEV's)	CL7-.../E	Low temperatures *	CL7-.../LT
Top wheels	CL7-.../T	90 degree gland	CL7-.../HWK
Side and top wheels	CL7-.../TZ	Silver graphite brushes	CL7-.../AG
Dust proof wheels	CL7-.../S	Special cable length	CL7-.../M
High travel speeds *	CL7-.../S	Transfer guide small (ITKN)	CLTK7-.../...
For galvanizing plants	CL7-.../V	Transfer guide large (ITN)	CLTG7-.../...
* from 100 m/min.		* from 100 m/min.	



Dove-tail connections



Extra wheel (.../E)



Top wheels (beared .../T/S, or not beared .../T)



Double top wheels with side wheels (.../TZ)

Collector Trolleys for Multiconductor

RNHS7 Type NLHS7-...-

For Multiconductor type RNHS7 special trolleys with an elongated lower moulding are utilized.

Collector Trolleys For Curves

Type S7-...-35

For installations with curves of a radius < 800 mm, special flexible current collectors are required. See also page 18. More information via TransTech.



NLHS7-7-35 (for RNHS7)



S7-4-35 (for BRN7)

Current Collecting Capacity Doubles When Parallel Connecting Copper Conductors.

A Multiconductor with 7 copper conductors offers the opportunity to double the current capacity when 3 phase by application of 2 conductors per phase in parallel. The 7th conductor is utilized for the ground supply. The extra capacity must be accounted for by selecting a suitable collector trolley.

A Max.	Type Collector Trolley	Number of Poles	Type Trans. Box
70	CL7-7-35	4	TTB70-4
140	CL7-7-70	4	TTB140-4-2
200	CL7-7-100	4	TTB200-4-6
280	CL7-7-70 2 pcs	4	TTB400-4-6
400	CL7-7-100 2 pcs	4	TTB400-4-6

Selection chart of 7-pole trolleys and transition boxes for installations with copper conductors in parallel for 3 phase + ground feed. Collector trolleys for special applications There is a number of possibilities to adapt the standard current collector series CL7. Wheel sets are available that can be mounted or exchanged easily by means of dove-tail connections (see photo). In the table below a number of special performances is listed with its respective suffix.

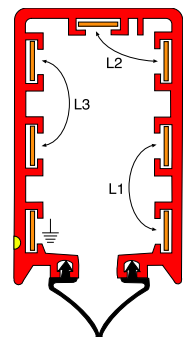

RN7-7-160/parallel

Collector Trolleys: Economic Collector Trolleys Series C4

If an application with TransTech Multiconductor requires no critical demands to the collector trolley, it is possible to apply a trolley of the C(L)4 series. These collector trolleys are available only for systems with 4 conductors. The 70A and 100A collector trolleys are formed by mounting 2 or 3 separate trolleys 35A on a metal strip (see the figures opposite).

It is recommended to use a transition box when connecting

the trolley with the apparatus to be fed. This box (order separately) can be mounted on the towing arm (see figure on page 13).

These collector trolleys are supplied with nylon wheels, suitable for travel speeds up to 60 m/min. For **higher travel speeds** and for **heavy duty environments** you should use collector trolleys of series 'C(L)7-.'. See page 10 and for more details.

Standard Collector Trolleys

Series C4 collector trolleys are available for 4 conductors with current carrying capacities of **35A, 70A, and 100A** (D.C. 60%). Applicable from -20°C up to +80°C. (See table on page 15 for trolley order information.)

These collector trolleys are fitted with a supply cable. The connection with the apparatus/machine to be fed is via a transition box (ordered separately) which can be located adjacent to the collector trolley towing arm position (see page 14).

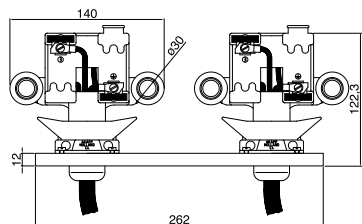

CL4-70

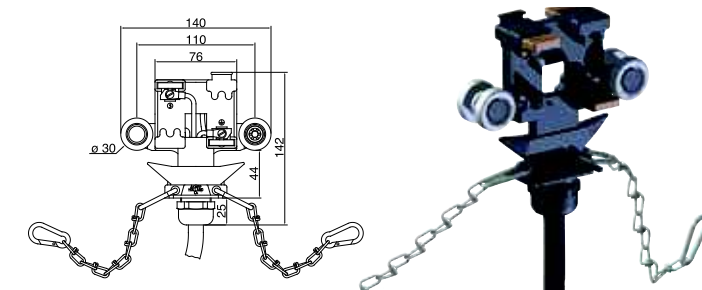

CL4-35



CL4-100

Carbon Brushes

The collector trolleys type CL4 are supplied as standard with carbon brushes for 35A, according to the table below.

Carbon Brush Type		Standard Brushes	
TransTech No.	Application	Brush Position in Collector Trolley	For Normal Conductors
A1411021	Phase brush compl.	1, 2, and 3	K91P
A1410521	Ground brush compl.	4	C91A

Transition Boxes for Collector Trolleys

This unit facilitates the connection of the flexible cable from the collector trolley with the fixed wiring from the apparatus/ machine being fed.

Using the included attachments, the transition box can be mounted easily on the (TransTech) towing arm or close to the apparatus/ machine.

Types of transition boxes:

Trans. Box Type	For Trolley	Inlet	Outlet
TTB35-4	C(L)4-35	1xM32	1xM32
TTB70-4	C(L)4-70	2xM32	1xM40
TTB100-4	C(L)4-100	3xM32	1xM40

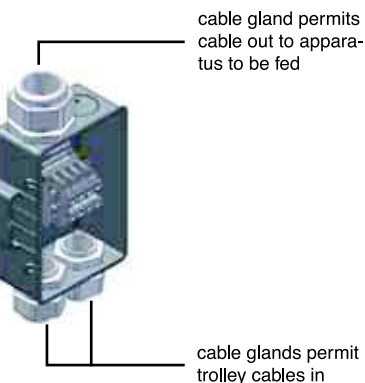
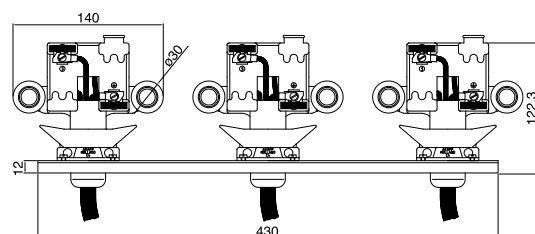

TTB70-4

Collector Trolleys Series CL4-40: The Compact Solution for Double Brushes Per Phase

TransTech offers the possibility to use a singular collector trolley, (type CL4-40), with double brushes. This trolley applies to the IEC 60204.32.13.8.2 standard, describing the situations whereas conductor bar systems need to apply double carbon brushes.

The CL4-40 trolley is a good and cost effective solution for those cases when the above standard is applied. In addition, the CL4-40 will improve the cost effectiveness of systems that are controlled by frequency inverters.

The CL4-40 is a 4 pole trolley, capacity 40 Amps at 60% duty cycle at 50 °C. Applicable from -20°C up to +80°C. The CL4-40 uses twin carbon brushes C91D for phases and special twin ground brushes C91DA.

All CL4-40 trolleys are available with cable lengths of 1, 2, 3, 4, or 5m. For standard cable length 1m you do not need to indicate anything. For other cable lengths add /2M, /3M, /4M or /5M to the type description.

Standard Collector Trolleys

Type CL4-40

4-pole trolley with standard wheels. Max. speed 100 m/min. For all RN-types of housings.

Type CL4-40/S

4-pole trolley with special ball bearing wheels. Max. speed 250 m/min. For all RN-types of housings.

Note: Trolleys without cable are also possible. Please cancel the "L" in the type description; e.g. type 'C4-40' is a 40 Amps trolley without cable.

Collector Trolley Assemblies

Type CL4-40/BMV/TTB

For easy ordering, we created a fully assembled version of the collector trolley CL4-40, complete with towing arm BMV35 and trolley transition box TTB70. See table below for order reference. For dimensions see table on page 14 (top).

Carbon Brushes And Wheel Sets

The following parts are applicable:

TransTech No.	Description	Type
A1410601	Carbon brush twin phase	C91D *
A1410631	Carbon brush twin ground	C91DA
A1630100	Wheel set standard (grey)	W *
A1630110	Wheel set high speed (blue)	WS *

* similar as on CL7 collector

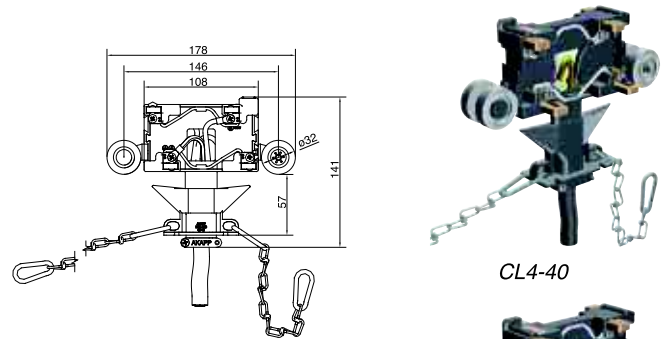

CL4-40



CL4-40/BMV/TTB



CL4-40/S

TransTech No.	Description	Extensions		Max. In (A) (DC=100%)	Number of Poles	Max. Speed (m/min)	Applicable For					
		Ext. 1	Ext. 2				Expansion Joint (KEV)	Dust Proof	Acid Proof	RNHS Profile	Data Silvered	Vertical Curves
A1088600	Collector trolley + cable			31.00	4	100	-	x	-	-	-	-
A1088600.B0002	Collector trolley + cable CL4-40	/2M		31.00	4	100	-	x	-	-	-	-
A1088600.B0003	Collector trolley + cable CL4-40	/3M		31.00	4	100	-	x	-	-	-	-
A1088600.B0004	Collector trolley + cable CL4-40	/4M		31.00	4	100	-	x	-	-	-	-
A1088600.B0005	Collector trolley + cable CL4-40	/5M		31.00	4	100	-	x	-	-	-	-
A1088620	Collector trolley + cable CL4-40	/S		31.00	4	250	-	x	-	-	-	-
A1088620.B0002	Collector trolley + cable CL4-40	/S	/2M	31.00	4	250	-	x	-	-	-	-
A1088620.B0003	Collector trolley + cable CL4-40	/S	/3M	31.00	4	250	-	x	-	-	-	-
A1088620.B0004	Collector trolley + cable CL4-40	/S	/4M	31.00	4	250	-	x	-	-	-	-
A1088620.B0005	Collector trolley + cable CL4-40	/S	/5M	31.00	4	250	-	x	-	-	-	-
A1088640	Assembly CL4-40/BMV/TTB			31.00	4	100	-	x	-	-	-	-

Accessories for Collector Trolleys: Towing Arms and Transition Boxes

A towing arm is attached to the moving machinery and connected to the collector trolley via chains.

The arrangement is such that when pulling in either direction, one of the collector towing chains is taut while the other remains slack.

This tolerance provides ultimate **security of service**.

Attention: The towing connector on the arm should be installed 10 mm lower than the towing connection on the

trolley in the highest position and 30 mm lower than the towing connection on the trolley in the lowest position and should be aligned directly below the housing opening in the vertical plane.

A transition box can be mounted on the towing arm or close by the apparatus/machine. This unit facilitates the connection of the flexible cable from the collector trolley with the fixed wiring from the apparatus/machine being fed.

Standard Performances Towing Arms

Type BMV35 for collector trolleys 35A

Type BMV70 for collector trolleys 70A

Type BMV100 for collector trolleys 100A

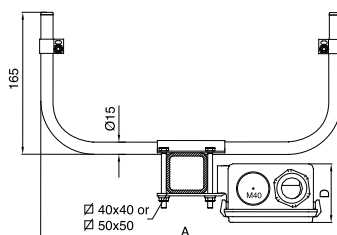

	BMV35 + TTB35	BMV70 + TTB70	BMV100 + TTB100
A	370	505	640
B	175	175	195
C	115	115	160
D	70	70	80
In	1xM32	2xM32	3xM32
Out	1xM32	1xM40	1xM40

Types of Transition Boxes for Collector Trolleys

Type No. Transition Box	Dimensions LxWxH MM	Connecting Terminals	Cable Inlet
TTB35-4 and TTB35-7	175x115x70	4 st. 4 mm ² 7 st. 4 mm ²	2 glands M32
TTB70-4 and TTB70-7	175x115x70	4 st. 10 mm ² 7 st. 10 mm ²	2 glands M32 1 gland M40
TTB100-4 and TTB100-7	195x160x80	4 st. 16 mm ² 7 st. 16 mm ²	3 glands M32 1 gland M40
TTB140-4-2	195x160x80	4 st. 35 mm ²	2 glands M32 1 gland M50
TTB200-4-6 and TTB200-7-6	300x250x145	4 st. bolts M10 7 st. bolts M10	6 glands M32 1 special inlet 20-70 mmØ
TTB400-4-6	300x250x145	7 st. bolts M10	6 packingb. M32 1 special inlet 20-70 mmØ

The box types TTB35 up to TTB140 can be mounted directly on the fastening clamp of the towing arm type BMV. The box types TTB200 and TTB400 are supplied with 4 holes Ø7 mm, which ensures easy mounting of these boxes to the apparatus to be fed.

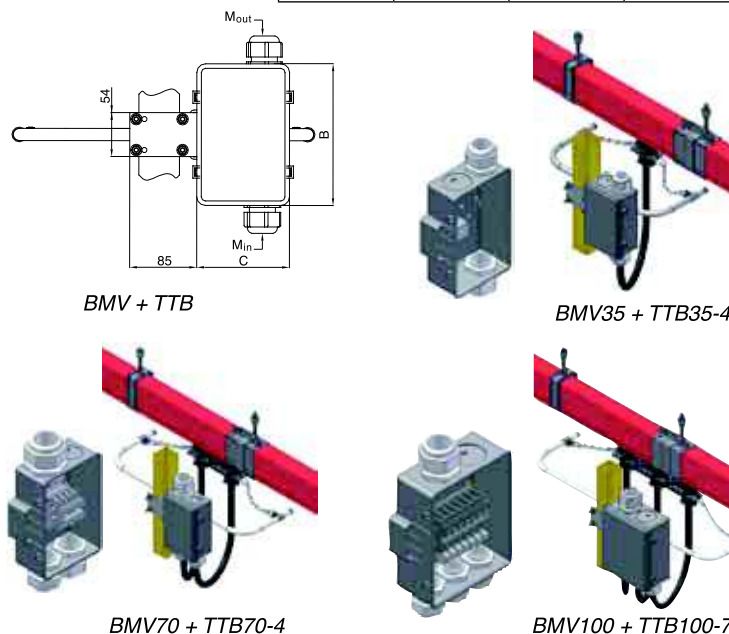

Spring Loaded Towing Arm

For installations with large transfer guides (type ITN7, see page 16) special spring loaded towing arms are supplied (see picture).

Type MVSP35 for trolleys 35A

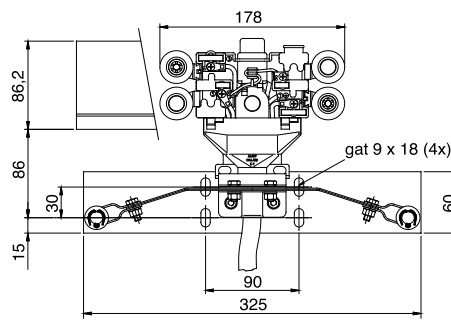

CL7-7-35 + MVSP

Overview Standard Collector Trolleys, Towing Arms and Transition Boxes

See the chart below for the most common standard collector trolleys of the series CL7 and NLHS7. The reference numbers and some details are listed for each type.

The other charts show all towing arms and transition boxes including their reference numbers.

Selection Chart Standard Collector Trolleys

TransTech No.	Description	CL	Max In (A) (Duty Cycle = 100%)	number of poles	max. speed m./min.	Applicable For					
						expansion joint (KEV)	transfer guides ITN7	Transfer guides ITKN7	HS, hand safe	Silvered	Vertical
A1088470	Collector trolley + cable	CL4-35	27.11	4	80	-	-	-	-	-	-
A1089360	Collector trolley + cable	CL4-70	54.22	4	80	-	-	-	-	-	-
A1089750	Collector trolley + cable	CL4-100	77.46	4	80	-	-	-	-	-	-
A1093440	Collector trolley + cable	CL7-4-35	27.11	4	100	-	-	-	-	-	-
A1093510	Collector trolley + cable	CL7-5-35	27.11	5	100	-	-	-	-	-	-
A1093580.B0000	Collector trolley + cable	CL7-6-35	27.11	6	100	-	-	-	-	-	-
A1093650	Collector trolley + cable	CL7-7-35	27.11	7	100	-	-	-	-	-	-
A1093860	Collector trolley + cable	CL7-4-70	54.22	4	100	-	-	-	-	-	-
A1093930.B0000	Collector trolley + cable	CL7-5-70	54.22	5	100	-	-	-	-	-	-
A1094000.B0000	Collector trolley + cable	CL7-6-70	54.22	6	100	-	-	-	-	-	-
A1094070	Collector trolley + cable	CL7-7-70	54.22	7	100	-	-	-	-	-	-
A1094280	Collector trolley + cable	CL7-4-100	77.46	4	100	x	-	-	-	-	-
A1094350.B0000	Collector trolley + cable	CL7-5-100	77.46	5	100	x	-	-	-	-	-
A1094420.B0000	Collector trolley + cable	CL7-6-100	77.46	6	100	x	-	-	-	-	-
A1094490	Collector trolley + cable	CL7-7-100	77.46	7	100	x	-	-	-	-	-
A1094720	Collector trolley + cable	CLTG7-4-35	27.11	4	100	-	x	-	-	-	-
A1094780.B0000	Collector trolley + cable	CLTG7-5-35	27.11	5	100	-	x	-	-	-	-
A1094840.B0000	Collector trolley + cable	CLTG7-6-35	27.11	6	100	-	x	-	-	-	-
A1094900	Collector trolley + cable	CLTG7-7-35	27.11	7	100	-	x	-	-	-	-
A1095120	Collector trolley + cable	CLTK7-4-35	27.11	4	100	-	-	x	-	-	x
A1095180.B0000	Collector trolley + cable	CLTK7-5-35	27.11	5	100	-	-	x	-	-	x
A1095240.B0000	Collector trolley + cable	CLTK7-6-35	27.11	6	100	-	-	x	-	-	x
A1095300	Collector trolley + cable	CLTK7-7-35	27.11	7	100	-	-	x	-	-	x
A1095480.B0000	Collector trolley + cable	CLTK7-4-70	54.22	4	100	-	-	x	-	-	x
A1095540.B0000	Collector trolley + cable	CLTK7-5-70	54.22	5	100	-	-	x	-	-	x
A1095600.B0000	Collector trolley + cable	CLTK7-6-70	54.22	6	100	-	-	x	-	-	x
A1095660	Collector trolley + cable	CLTK7-7-70	54.22	7	100	-	-	x	-	-	x
A1095840.B0000	Collector trolley + cable	CLTK7-4-100	77.46	4	100	-	-	x	-	-	x
A1095900.B0000	Collector trolley + cable	CLTK7-5-100	77.46	5	100	-	-	x	-	-	x
A1095960.B0000	Collector trolley + cable	CLTK7-6-100	77.46	6	100	-	-	x	-	-	x
A1096020	Collector trolley + cable	CLTK7-7-100	77.46	7	100	-	-	x	-	-	x
A1072020.B0000	Coll. trolley for RNHS7	NLHS7-4-35	27.11	4	100	-	x	x	x	-	-
A1072170.B0000	Coll. trolley for RNHS7	NLHS7-5-35	27.11	5	100	-	x	x	x	-	-
A1072250.B0000	Coll. trolley for RNHS7	NLHS7-6-35	27.11	6	100	-	x	x	x	-	-
A1072330	Coll. trolley for RNHS7	NLHS7-7-35	27.11	7	100	-	x	x	x	-	-
A1076820.B0000	Coll. trolley for RNHS7	NLHS7-4-70	54.22	4	100	-	-	x	x	-	-
A1076970.B0000	Coll. trolley for RNHS7	NLHS7-5-70	54.22	5	100	-	-	x	x	-	-
A1077010.B0000	Coll. trolley for RNHS7	NLHS7-6-70	54.22	6	100	-	-	x	x	-	-
A1077160.B0000	Coll. trolley for RNHS7	NLHS7-7-70	54.22	7	100	-	-	x	x	-	-
A1080430.B0000	Coll. trolley for RNHS7	NLHS7-4-100	77.46	4	100	x	-	x	x	-	-
A1080510.B0000	Coll. trolley for RNHS7	NLHS7-5-100	77.46	5	100	x	-	x	x	-	-
A1080660.B0000	Coll. trolley for RNHS7	NLHS7-6-100	77.46	6	100	x	-	x	x	-	-
A1080740.B0000	Coll. trolley for RNHS7	NLHS7-7-100	77.46	7	100	x	-	x	x	-	-

Selection Chart Towing Arms

TransTech No.	Description		Collector Trolley
A1019050	Towing arm	BMV35	...35/...40
A1019130	Towing arm	BMV70	...70
A1019210	Towing arm	BMV100	...100
A1018940	Towing arm, stainl.st.	BMV35-R	...35
A1019830	Towing arm, stainl.st.	BMV70-R	...70
A1019910	Towing arm, stainl.st.	BMV100-R	...100

Selection Chart Transition Boxes

TransTech No.	Description	
A1020000	Transition box for collector trolleys	TTB35-4
A1020010	Transition box for collector trolleys	TTB35-7
A1020020	Transition box for collector trolleys	TTB70-4
A1020030	Transition box for collector trolleys	TTB70-7
A1020040	Transition box for collector trolleys	TTB100-4
A1020050	Transition box for collector trolleys	TTB100-7
A1020060	Transition box for collector trolleys	TTB140-4-2
A1020090	Transition box for collector trolleys	TTB200-4-6
A1020100	Transition box for collector trolleys	TTB200-7-6
A1020120	Transition box for collector trolleys	TTB400-4-6

Transition boxes for collector trolleys, not to be mounted on the towing arm. Cable shoes are not included. See page 14 for more information.



Other Components: Transfer Guides

Transfer guides are for the passage of collector trolleys through conductor transfers, on turn or slide switches for example (see drawing). The type is related to the mechanical tolerance of the transfer system itself.

Type ITN7

Suitable for mechanical tolerances vertical and horizontal planes of less than 10 mm; infinite gap.

Type ITNHS7

for Multiconductor RNHS7

Type ITKN7

Suitable for mechanical tolerances, vertical and horizontal planes less than 2 mm and gap less than 3 mm.

Type ITKNHS7

for Multiconductor RNHS7

N.B.1. It is important to consider the travel speed on transfer systems.

N.B.2. The transfer guides are not suitable for switching higher currents.

This transfer guide includes: 1 trumpet to which is fitted 500 mm of housing RN7, in which are already fitted copper conductors Cu 125 (ITN7) or Cu80 (ITKN7), 500 mm of housing RN7 to attach the transfer guide section to the Multiconductor (incl. mounting material). To be ordered separately: a line feed box for shrouding the connection between the trumpet housing and opposite RN7-housing and 2 fixed point clamps to be placed on each side of the line feed.

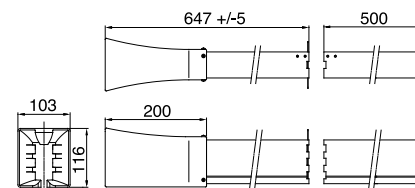
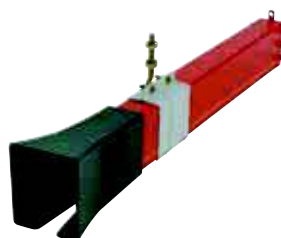
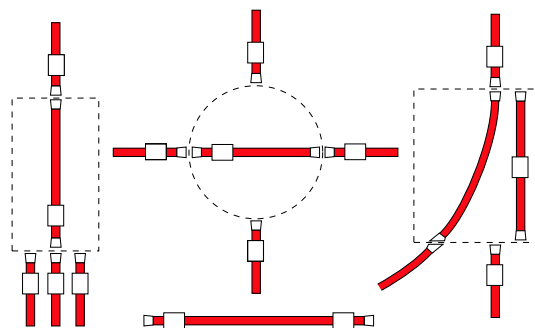

TransTech No.	Description	left	right	space between transf.guides <= 3mm	vertical tolerance <= 2mm	horizontal tolerance <= 2mm	red	white	length m	min. temperature °C	max. temperature °C	max. number of poles	protection degree IP23	sealing rubber AS7 applicable	HS, extra protection
A1016310	Transfer guide large red ITN7-L	x					x		1.15	-30	60	7	x	x	
A1016540	Transfer guide large red ITN7-R		x				x		1.15	-30	60	7	x	x	
A1017820	Transfer guide large red ITN7-N	x	x				x		1.15	-30	60	7	x	x	
A1017830.B0000	Transfer guide large, ITN7W-L	x						x	1.15	-30	60	7	x	x	
A1017840.B0000	Transfer guide large, ITN7W-R		x					x	1.15	-30	60	7	x	x	
A1016770.B0000	Transfer guide f. RNHS7 ITNHS7-L	x					x		1.15	-30	60	7	x	x	x
A1017510.B0000	Transfer guide f. RNHS7 ITNHS7-R		x				x		1.15	-30	60	7	x	x	x
A1016630.B0000	Transfer guide vicat ITNV7-L	x							1.15	-20	80	7	x	x	
A1016640.B0000	Transfer guide vicat ITNV7-R		x						1.15	-20	80	7	x	x	
A1017040	Transfer guide small red ITKN7-L	x		x	x	x	x		1.025	-30	60	7	x	x	
A1016930	Transfer guide small red ITKN7-R		x	x	x	x	x		1.025	-30	60	7	x	x	
A1018470	Transfer guide small red ITKN7-N	x	x	x	x	x	x		1.025	-30	60	7	x	x	
A1017270.B0000	Transfer guide f. RNHS ITKNHS7-L	x		x	x	x	x		1.025	-30	60	7	x	x	x
A1018710.B0000	Transfer guide v.RNHS ITKNHS7-R		x	x	x	x	x		1.025	-30	60	7	x	x	x

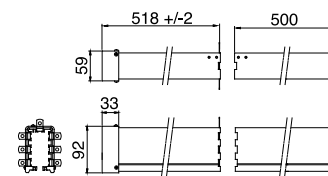
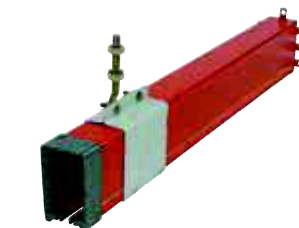

This transfer guide includes: 1 trumpet to which is fitted 500 mm of housing RN7, in which are already fitted copper conductors Cu 125 (ITN7) or Cu80 (ITKN7), 500 mm of housing RN7 to attach the transfer guide section to the Multiconductor (incl. mounting material). To be ordered separately: a line feed box for shrouding the connection between the trumpet housing and opposite RN7-housing and 2 fixed point clamps placed each side of the line feed.

Other Components: Conductor Isolation Sections

Copper conductors isolation sections are used in the event of an electrical division between one single or various conductors.

Two models are available:

SO7 - for electrical isolation of 1 - 7 strips

SO1/SRN1 - for electrical isolation of 1 strip

It is important to consider the correct compensation for the expansion differences.

If one or more isolation sections are applied, we strongly recommend that you send us a situation drawing of the feeding system in order to determine the correct execution.

Conductor Isolation Sections

Type SO7

This isolation section is fitted into a Multiconductor between 2 housings RN7. This section is shrouded with one of the line feed boxes (see page 6, ordered separately) on each side of which a fixed point clamp is positioned (2 pc., ordered separately).

Type SOHS7 for Multiconductor RNHS7.

Similar to SO7, with additional spacer strips at the bottom for use with extra hand-safe housing RNHS7.

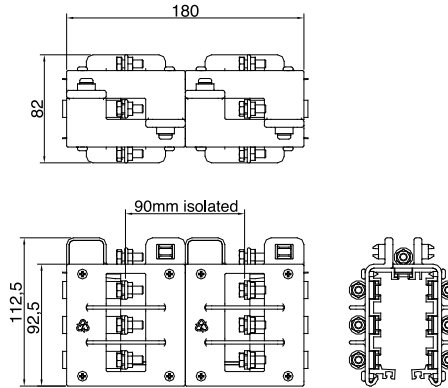

SO7

Special Conductor Isolation Sections:

Type SO1

In case only one or two isolations in the controlling current conductors are required, these small isolation sections can be used. At the position of the required isolation, slots are made in the housing, through which the copper conductors are bent outwards. A small isolation section is then placed between the conductors, after which the assembly is enclosed by a small cover (45x38x20 mm). Connection of a supply cable is possible by piercing a hole in the cover. When sealed with silicone-mastic (not supplied) this unit is also suitable for outdoor installations.

Type SRN1

This prepared housing (200 mm length) is available as an alternative to cutting slots in the standard housing and is fitted in the Multiconductor by means of 2 joint clamps type VN7.

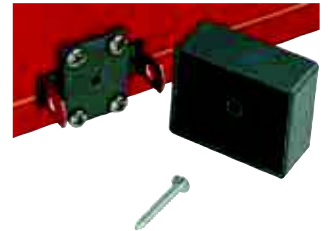
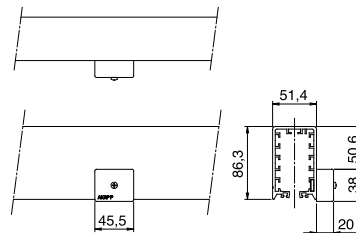

SO1

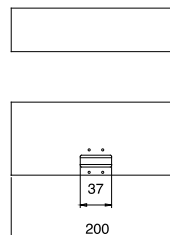

SRN1

NOTE: The conductor isolation section is not suitable for switching higher currents.

Curved Tracks: Horizontal and Vertical

The Multiconductor is also used for curved installations such as i.e. at concrete skipper installations. In general, the curved segments are made to measure in the required radius.

A correct drawing is therefore of utmost importance.

Horizontal curves do not have a marking strip and no antireverse rib in the conductor. This implicates that it is not required to take the positioning into consideration with regard to the other conductor segment when ordering.

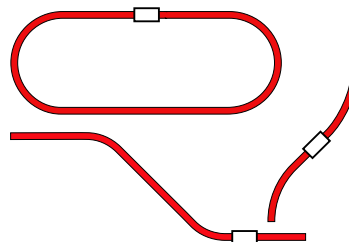

Curved Housings

Type BRN7- (radius)

Horizontal curves are available from R=600 mm and vertical curves from R=1800 mm (center sizes, see drawing).

In curves the center distance of the hanger support varies from 600 - 1000 mm (in general min. 2 hanger supports per curved section).

Vertical curves exist in 2 varieties:

concave: biggest radius at the bottom (=opening) of the housing;

convex: smallest radius at the bottom of the housing. See drawings.

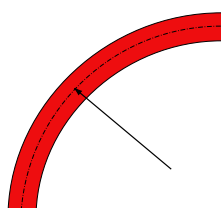

Horizontal curve BRN7

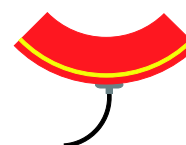

vertical curve, concave

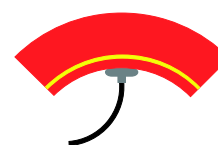

vertical curve, convex

Type BRNHS7- .. (Radius)

Curves for Multiconductor RNHS7.

Collector Trolleys In Installations with Curves

For installations with curves, only 35A collector trolleys should be used. It is possible to use more collector trolleys in parallel for higher current capacities. For curves with bending radius <800 mm the flexible trolley type S7-...-35 is used (see photo). See also page 11.



S7-4-35

Copper Conductors In Curved Tracks

In horizontal curve installations, it is preferred to not use the top conductor channel. If you need 3 conductors, choose 4; if you need 5, choose 6 and avoid using the top slot. If the top slot must be used and radius is less than allowed in table, conductors must be supplied pre-bent. However, this depends on radius of the curve as well as on the thickness of the conductors. Please contact TransTech for details. For vertical curves less than the radius allowed in the table, conductors must be supplied pre-bent. See table

In all other cases, the copper conductors can be rolled directly from the drum through the curves.

Pre-bent strips are required for installations with following conductors and radii (horizontal or vertical):

Type of Copper Conductor	Curves Up To Radius R
Cu35 *	1200 mm
Cu50 *	1500 mm
Cu80	2000 mm
Cu125	2500 mm
Cu160	3000 mm

* Copper conductors Cu35 and Cu50 cannot be prebent. If required, Cu80 shall be applied in the curve(s).

Installation Tools: For Optimal Efficiency

The Multiconductor is easily installed. All components have been designed so that a combined installation is perfectly suitable.

Several operations during the installation process may be even more efficient if you opt for the auxiliary tools detailed below.

It is important to use the products as detailed below whenever possible. You could save time. Read the instructions carefully and prior to the use of said products.

Should you have any questions, please feel free to contact TransTech.

Copper Pulling-Cassette

This device can be included in all new installations of the TransTech Multiconductor. The copper rolls are placed onto the cassette after which the roll will be rolled off smoothly. The roll is provided with a feed-through aperture. A limiter prevents the rolling off of the roll onto the platform.

Copper Pulling-Block

In order to ease the pulling of the copper conductor into the copper channels of the Multiconductor, a wooden pulling block can be included in all new complete installations. This pulling block includes a drawbar eye into which a rope can be attached. To be used in combination with the aforementioned copper pulling cassette.

Pressing Tool for Sealing Strips

To be used for the easy application of the flexible rubber seal AS7 to the bottom side of the Multiconductor. In one single movement, the rubber strips can be applied to both rubber channels of the Multiconductor.

Copper Straightener

It is strongly recommended to use this tool for the easy mounting of the copper conductors 125A and 160A in the Multiconductor. The stretcher eliminates the ridged form of the copper during the mounting. This is especially important for track lengths over 50 meters.

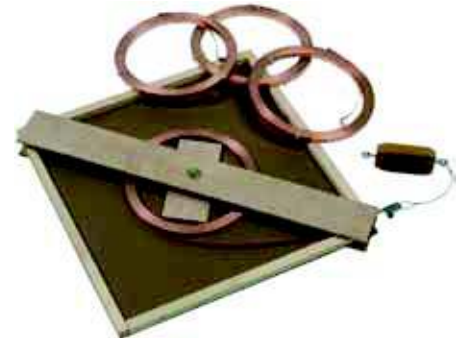

Cu200	Cu160	Cu125	Cu80	Cu50	Cu35	Partner	Cassette
-	-	-	90	145	240	A1039820.B000	50x50 cm Copper cassette, small core
60	100	130	230	350	540	A1040220.B000	80x80 cm Copper cassette, large core
100	200	260	470	740	1300	A1040450.B000	100x100 cm Copper cassette, large core

TransTech No.	Description	Length >25m	AS7	HS	Cu125	Cu160
A1003610	Copper Pulling-Block	x				
A1003760	Tom thumb	x	x			
A1003800	Tomb thumb for RNHS5/7	x	x	x		
A1003950	Straightening device STR160 for Cu125 and Cu160	x				x

**More On Multiconductor:
Technical Data and Ordering References**

General Technical Data

Nominal voltage: 660 Volt. Under humid conditions and on all outdoor installations for the 6 and 7-pole Multiconductor systems: 500 Volt.

For further technical details refer to the components description in this catalog.

Comprehensive installation instructions will accompany every Multiconductor system.

System Extensions

It is generally possible to increase the length of an existing system utilizing standard components. Please consult the TransTech sales office giving full details of the existing system and required extension.

Design And Dimensions

We reserve the right to amend dimensions/design of components in the interests of design advancement without prior notification.

Multiconductor Internal Heating

In extreme applications where condensation and ice needs to be prevented, the Multiconductor can be heated along a part or the entire length of the system.

Type ESR20 (A), Insulated.

For up to 6-pole systems. 1 channel fitted with heating strip, covered with plastic strip. Max. track length 60 m. Connecting voltage: AC 230V. Automatic control of required capacity based on the ambient temperature. Capacity 10W/m at +10°C.

Type VB7 (B), Insulated.

For up to 7-pole systems. Pull into slot next to anti-reverse rib. Max. track length 80 m. Connecting voltage AC 230V. Self regulating. Capacity 23W/m at +5°C.

Type SS TAPE (C), Not Insulated.

For systems including a minimum of 2 free channels. Stainless steel strip 13x0.5mm; R=0.1106 Ω/m. Not self regulating; transformer and thermostat needed (not included).

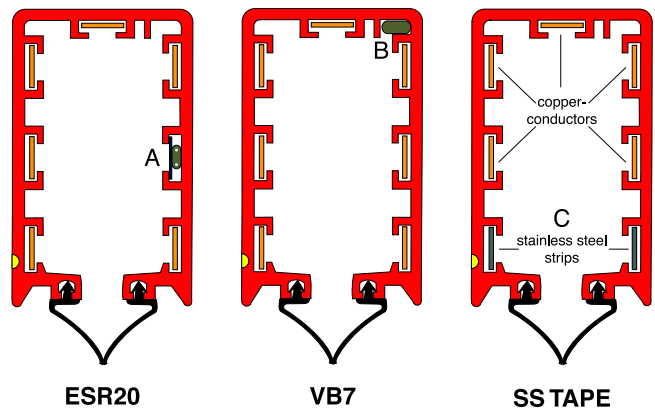

Example for Ordering Indoor Installation

1 TransTech Multiconductor type RN7-4-35, 3 phase + ground, without flexible sealing strips, track length 50 m, 4 poles, nominal capacity up to 35A, duty cycle 80%, with end feed. Apparatus to be fed: 1 overhead crane, maximum total power 7.5 kW, 400V, speed 40 m/min, in warehouse, dry, no excessive dust, ambient temperatures from +10°C up to +35°C. Supports every 2m.

The installation consists of:

- 48 m type RN7 PVC housing (12 x 4 m)
- 2 m type RN7 PVC housing (1 x 2 m)
- 200 m type Cu35 copper conductor 35A (4 x 50 m)
- 25 pcs type BN7-Z sliding hangers, galvanized
- 13 pcs type VN7-Z joint clamps, galvanized
- 1 pc type VMN7-Z fixed point clamps, galvanized
- 1 rl type T50 isolation tape (10 m)
- 1 pc type EBS32 end feed box
- 1 pc type EN7 end cap
- 1 pc type CL4-35 collector trolley
- 1 pc type BMV35 towing arm
- 1 pc type TTB35-4 transition box
- also recommended:
- 26 pcs type UH330 support brackets

Example For Ordering Outdoor Installation

1 TransTech Multiconductor type RN7-5-125, 3 phase, neutral, ground, with flexible sealing strips, track length 85 m, 5 poles, nominal capacity up to 125A, duty cycle 80%, with line feed at 24 m. Apparatus to be fed: 2 cranes, 25 kW each, 400V, speed 90 m/min, in concrete industry, alternate dusty, humid and corrosive, ambient temperatures from -15°C up to +35°C. Supports every 1.33 m.

The installation consists of:

- 84 m type RN7 PVC housing (21 x 4 m)
- 1 m type RN7 PVC housing (1 x 1 m)
- 1 pc type RN7-LCH line feed clamp holder
- 170 m type AS7 flexible sealing strips (2 x 85 m)
- 425 m type Cu125 copper conductor 50A (5 x 125 m)
- 64 pcs type BN7-L sliding hangers, galv. + coated
- 22 pcs type VN7-L joint clamps, galv. + coated
- 2 pcs type VMN7-L fixed point clamps, galv. + coated
- 1 rl type T50 isolation tape (10 m)
- 1 pc type LB63 line feed box
- 5 pcs type LC200 feed clamps
- 2 pcs type EN7 end caps
- 2 pcs type CL7-5-70 collector trolleys
- 2 pcs type BMV70 towing arms
- 2 pcs type TTB70-7 transition boxes
- also recommended:
- 66 pcs type UH500 support brackets

Installation Examples: System Configuration

The construction method to be used with the TransTech Multiconductor is based on “controlled expansion”. This guarantees the solution of expansion related problems which coincide with three different elements: synthetics, copper, and suspension frame. The linear expansion and shrinking of the PVC conductor housing is 0.07 mm/°C/m, which is the 5-fold of copper conductors to be mounted into the conductor housing as well as the suspension frame.

The TransTech Multiconductor design permits the free movement of the three elements thus resolving problems often experienced with other systems.

Most common installations with one feed point at the end or somewhere along the installation (see illustration below, examples A or B) are mounted on the basis of free expansion. The expansion movement takes place from the fixed point. Maximum lengths for application of **fixed** joints type VN7 are mentioned in the list on page 2.

For installations where the required system is longer than stated in this list or where similar to one of the applications C up to F, please refer to the TransTech sales office for additional installation instructions.

Multiconductor System Construction

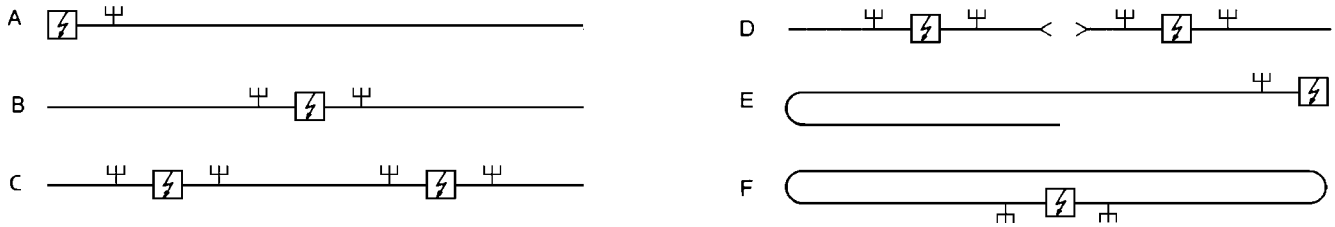

Multiconductor System Configuration End Feed

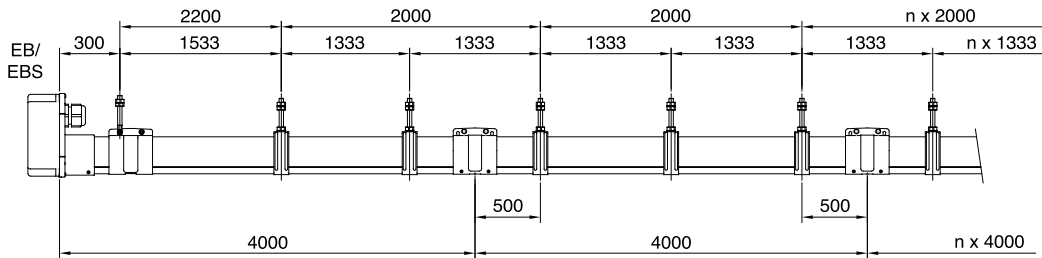

Multiconductor System Configuration Line Feed

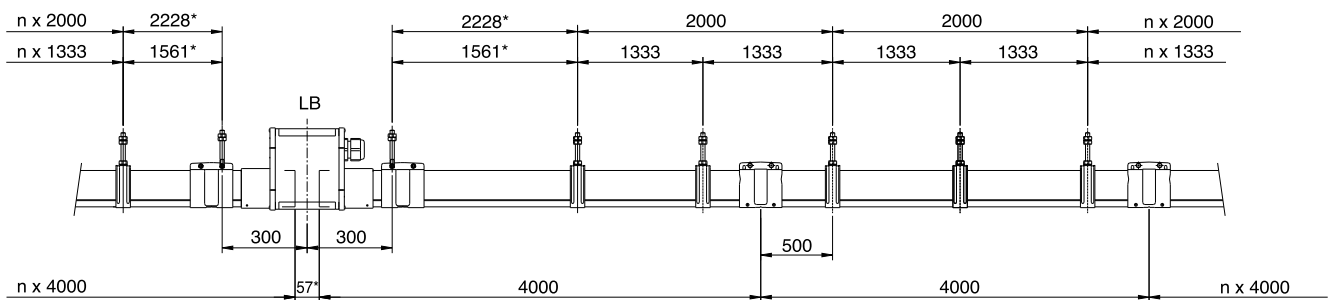

With TransTech Multiconductor an optimum reliability is achieved by the unique composition of this conductor system. We offer our experience following many years of service to industry, covering practically all types of ambient conditions.

Appendix: Maintenance and Spare Parts of Collector Trolleys

When replacing or revising a TransTech collector trolley, the information below needs your special attention to prevent accidents or failures of the installation.

Older trolley models (series "S") have a different numbering of

the cable wires to the brushes.

The table below displays all information concerning the spare parts, used in each trolley model.

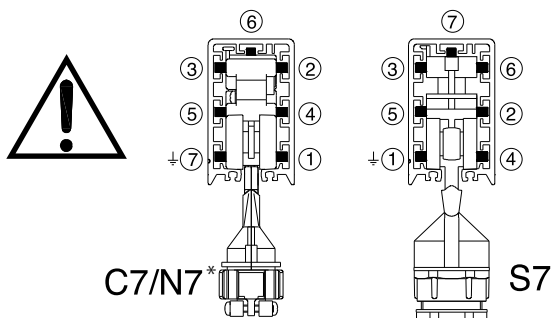

Attention!

Trolley type S7 has different cable numbering. Please check before installing that the internal wiring of the trolley is correct!

Length of the towing chains for 35A trolleys is 5 links and for 70A and 100A trolleys 6 links.

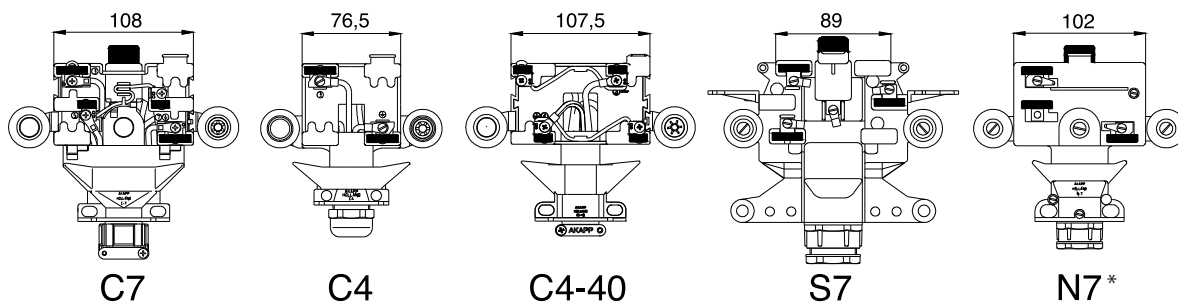

TransTech No.	Type	Description	C7	C4	C4-40	S7	N7
A1411021	K91P	Carbon brush phase	x	x			x
A1410521	C91A	Carbon brush ground	x	x			
A1410601	C91D	Carbon brush twin phase	x		x		
A1410631	C91DA	Carbon brush twin ground			x		
A1412061	K91A	Carbon brush ground					x
A1410130	B91SP	Carbon brush phase				x	
A1410210	B91SA	Carbon brush ground				x	
A1410050	B91SN	Carbon brush neutral				x	
A1630100	W	Wheel set	x		x		
A1630110	WS	Wheel set ball bearing	x		x		
A1630120	WZ	Wheel set + side wheel	x		x		
A1630130	WSZ	Wheel set ball bearing + side wheel	x		x		
A1096550	WE	Set middle wheel	x				
A1096500	BG	Set bow	x				
A1331930	G	Gliding shoe	x		x		
A1510460		Wheel C4		x			
A1510230		Wheel				x	

*N7 is a discontinued item, and, in most cases, can be replaced by the C7 (despite the length differences). Contact TransTech with any questions.

Special Applications: The Sky is the Limit!

TransTech Multiconductor can be applied in installations with transfer guides, horizontal, and/or vertical curves. Even closed curved tracks are a possibility!

Your specific configuration can be detailed and adjusted by our professionals to become a perfect fitting installation!
For further information, please contact TransTech!



Four closed curved tracks for feeding of a rotating elevator.



Curved installation for window cleaning equipment



A 500 m long enclosed track for a passenger train in the zoo



Feed and control of bridge cranes in a galvanizing plant



Feed and control of a concrete skipper



TranstTech
POWER TRANSFER SYSTEMS

The Leaders In Power Transfer Technology

TranstTech is a subsidiary of Fandstan Electric, a global group of companies focusing on energy transfer systems with installations in over 100 countries. Working synergistically with our European sister companies such as Brecknell-Willis, Stemmann and AKAPP, we are able to leverage a broad product portfolio and a wealth of technical expertise. Our goal is to better serve our power transfer markets by continuing to provide solutions that improve product life, performance, and reliability.

709 Augusta Arbor Way
Piedmont, SC 29673

800.245.4552 ph | 864.277.7100 fx
transtech.com

A Fandstan Electric Company